

ApolloSprayers Turbine Instruction Manual



TABLE OF CONTENTS

Safety Warnings.....	1
Grounding Instructions.....	2
TrueHVLP™ Spray Finishing Systems.....	3
How Your HVLP Turbine System Works.....	3
How Your Spray Gun Works.....	4
Preparing to Use Your HVLP Turbine System.....	4
Familiarize Yourself with Your TrueHVLP™ Spray Gun.....	4
Handi-Hold Spray Gun Docking Station.....	5
Apollo Turbine Models 725 and 825.....	6
Apollo Turbine Models 1025 and 1040VR.....	7
Apollo Turbine Model 800S and 1000S.....	8
Apollo Turbine Models 900, 1100 and 1200	9 &10
Know Your Coatings/Coating Properties	10
Coatings and Viscosity/Turbine Performance and Properties	11
Using Latex (Emulsion) Paint and Nozzle, Needle & Air Caps for 5000 Series	11
Nozzle, Needle & Air Caps for 7500 Series/Viscosity.....	12
Spraying Technique	13
Cleaning Your TrueHVLP™ Spray Gun.....	14
Using Pressure Pots with Turbine Systems.....	14
Recording Turbine Use and Maintenance	15
Turbine Maintenance and Cleaning, After Use/Pre-Filter.....	16
Filter Maintenance / 800S & 900S/Annual Maintenance.....	17
Model 725 Diagram and Parts List.....	18
Model 825 Diagram and Parts List.....	19
Model 900 Diagram and Parts List.....	20
Model 1025 Diagram and Top Wiring.....	21
Model 1025 Parts List.....	22
Model 1100 Chassis Diagrams.....	23
Model 1100 Turbine and Air Hose Diagram.....	24
Model 1100 Parts List.....	25
Model 1200 Chassis Diagram.....	26
Model 1200 Top, Fluid Hose and Air Hose Diagrams.....	27
Model 1200 Parts List	28
Model 1040VR Diagram and Parts List.....	29
Running Multiple Spray Guns with a Turbine	30
Genuine Apollo Accessories.....	30&31
Warranty.....	32



Read all instructions and safety precautions before operating the unit.



THIS INDICATES A CONDITION THAT WILL CAUSE SERIOUS INJURY OR LOSS OF LIFE IF THE WARNING IS IGNORED.



THIS INDICATES A CONDITION THAT COULD CAUSE SERIOUS INJURY OR LOSS OF LIFE IF THE WARNING IS IGNORED.



THIS INDICATES A CONDITION THAT MAY CAUSE MINOR INJURY AND/OR EQUIPMENT/PROPERTY DAMAGE.



- Risk of fire or explosion! Solvent and paint fumes can explode or ignite, causing severe injury and property damage.
- Paints and solvents containing HALOGENATED HYDROCARBONS can react explosively with aluminum. Always check the product's label before using these materials in the unit.



- Hazardous vapors: Paint, solvents, insecticides and other materials may be harmful if inhaled, causing severe nausea, fainting or poisoning.

- Make sure the room is well ventilated. Avoid all ignition sources, such as static electricity, sparks, open flames, hot objects, sparks from connecting and disconnecting power cords, and working light switches.

- Follow the material and solvent manufacturers' safety precautions and warnings. Do not use liquids with flash points less than 100 degrees Fahrenheit (38 degrees Celsius).



- Static electricity can be produced by HVLP spraying. Make sure any electrically conductive object being sprayed is grounded to prevent static sparking. The sprayer is grounded to prevent static sparking. The spray is grounded through the electrical cord.

- Use a respirator or mask whenever there is a chance that vapors may be inhaled. Read all instructions with the mask to ensure that the mask will provide the necessary protection against the inhalation of harmful vapors.



- Do not carry the turbine while spraying.
- Keep the turbine at the maximum distance from the spraying area.



- Tipping the spray gun causes the spray gun to clog. Dried spray material also clogs the pressure delivery tube and fittings. The spray gun does not function when clogging occurs.
- When not in use, be sure to disconnect the hose and place the spray gun into the Handi-Hold Docking Station on the turbine to avoid tipping.

⚠ DANGER

IMPROPER INSTALLATION OF THE GROUND PLUG CAN RESULT IN THE RISK OF ELECTRICAL SHOCK. IF REPAIR OR REPLACEMENT OF THE PLUG OR CORD IS NECESSARY, DO NOT CONNECT THE GROUND WIRE TO EITHER FLAT BLADE TERMINAL. THE WIRE WITH GREEN INSULATION (WITH OR WITHOUT A YELLOW STRIPE) IS THE GROUNDING WIRE.

1. For any question regarding proper installation of the ground plug, consult a qualified (licensed or certified) electrician.
2. Do not modify the plug provided. If the plug does not fit the outlet, have the proper outlet installed by a qualified electrician.



3. This product is for use on a nominal 110-volt circuit and has a grounding plug that looks like the plug in Figure 2. Make sure that the product is connected to an outlet having the same configuration as the plug. No adapters should be used with this product.

4. If an extension cord is required, use only a three wire extension cord that has the same configuration as the unit cord, including the (round) ground terminal. Make sure that the extension cord is plugged into a properly grounded receptacle.
5. When using an extension cord, be sure it is in good condition and heavy enough to meet the specifications in the chart below. If an extension cord is needed the following wire sizes must be used.

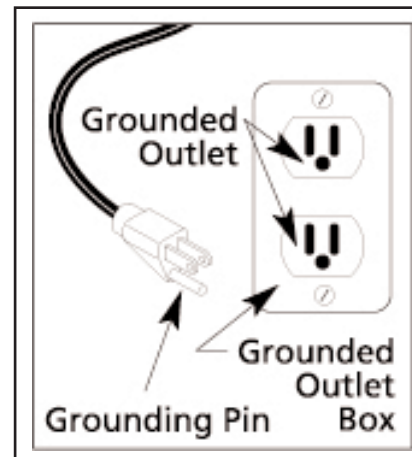

Figure 2

6. (See **CHART 1**)

25' cord (7.62m).....	10, 12, or 14 Gauge
50' cord (15.24m).....	10 or 12 Gauge
100' cord (30.48m).....	10 Gauge

CHART 1 EXTENSION CORD REQUIREMENTS

GROUNDING INSTRUCTIONS FOR ALL COUNTRIES USING A 2 PRONGED PLUG CONFIGURATION

⚠ CAUTION

This product must be properly grounded. In the event of an electrical short circuit, grounding reduces the risk of electrical shock by providing an alternate path for the electrical current.

This product is equipped with a cord that has a ground wire and an appropriate ground plug. Plug the unit into an outlet that is properly installed and grounded in accordance with local codes and ordinances.

Safety Note: Users in countries in continental Europe and Australia and anywhere that offers a two pronged plug should be aware that this configuration does not provide grounding.

TrueHVLP™ SPRAY FINISHING SYSTEMS

CONGRATULATIONS!! You have just purchased the finest HVLP air turbine system available. You are about to enjoy the great benefits of TrueHVLP™. Our designs are the result of many years experience in manufacturing HVLP turbine systems, and HVLP spray guns. We have painstakingly worked and consulted with professional spray finishers to bring you this versatile, well engineered tool.

Whether you are new to spray finishing, whether you have spray finished before, or are just new to HVLP spraying, there are some basic spray finishing guidelines that will help you to achieve the best results and optimum success from your new equipment. Reading this information carefully and following these simple steps will ensure that you get the best performance and results from your new TrueHVLP™ spray system.

INSTRUCTIONS

Check the contents of your box. The following are included:

- Turbine Unit
- Spray Gun
- Air Hose
- Instruction Manual

HOW YOUR HVLP TURBINE SYSTEM WORKS

Your turbine system has three components: the turbine unit, an air hose and a spray gun. The turbine unit, when connected to the correct electrical power supply and with the on/off switch in the “on” position, provides a continuous source of clean, warm, dry, High Volume Low Pressure air. The air hose connects the turbine unit to the spray gun. Air flows through the hose to the nozzle of the specially designed TrueHVLP™ spray gun. Atomization of the coating is achieved when the air mixes with the stream of fluid passing through the tip/nozzle. This low pressure atomization principle achieves minimum misting (overspray) to the spray environment.



HOW YOUR SPRAY GUN WORKS

Apollo offers two types of Turbine Spray Guns. The 5000 series and the 7500 series. The 5000 series spray guns are bleeder style. When the turbine blower is turned “on” air will constantly flow through the air cap. The 7500 series spray guns are non-bleeder style. When the turbine blower is turned “on” air will only flow through the air cap when the trigger on the spray gun is activated or pulled back. Air also flows through the air feed tube to pressurize the cup and deliver fluid to the tip/nozzle. When the paint flow screw is opened and the trigger pulled back, fluid flows through the tip/nozzle mixing with the air flow delivered from the air cap and projects a fine atomized mist to your work piece. Spray pattern control will vary depending on the spray gun model. Consult your individual spray gun manual for detailed operation and maintenance of your spray gun.

PREPARING TO USE YOUR HVLP TURBINE SYSTEM

Connect the air hose to the turbine. Pull back the spring loaded quick disconnect coupler and insert the male connector on the air hose into the turbine connector. Release the ring. Your air hose will be locked into place. To release the air hose, pull back on the spring loaded quick coupler ring with your fingers and pull.



Do not cover or enclose the turbine. It is important to draw cool/ambient air through the unit for optimum performance. Avoid placing the turbine in a warm environment or in direct sunlight.

FAMILIARIZE YOURSELF WITH YOUR TrueHVLP™ TURBINE SPRAY GUN

Refer to your Spray Gun Instruction Manual for information, setup and operation of your model spray gun.

You should now be ready to spray your coating of choice on your work piece. Good quality results with your TrueHVLP™ spray finishing equipment are a combination of careful preparation of your project, a proper spraying environment, a basic knowledge of the coatings you will be using and how these coatings work with your TrueHVLP™ spray equipment.



Even when the turbine unit is turned off, pressure will remain in the spray cup. If you pull the trigger back, a stream of fluid will flow. To prevent accidents, turn material flow screw clockwise until it is completely closed. The trigger is now locked in the closed position.

Note: It is not necessary to empty and clean your spray gun when you pause between applications. Be sure, however, to clean your spray gun thoroughly at the end of your work session. It is a bad idea to leave material in your spray gun overnight. Extra caution should be taken when spraying coatings that have a catalyst or hardener added since many of these coatings have a short pot life. These coatings can harden in your spray gun quickly, making cleaning difficult or impossible. Read manufacturer’s coating instructions as to how much time you have before catalyst/hardener begins to set up.

GET TO KNOW YOUR TURBINE

HANDI-HOLD SPRAY GUN DOCKING STATION

Every model of Apollo Turbine except for the 800S and 1000S comes equipped with the Handi-Hold™ Spray Gun Docking Station, Apollo's smart innovation. Store, hold or transport your spray gun in a vertical position with no risk of it falling over. Ready to spray when you are.



APOLLO HVLP TURBINES

Each TrueHVLP™ Turbine Unit offers the finisher a maximum operating pressure. This pressure is determined by the size and output of the unit you have selected. The maximum available pressure will have a direct bearing upon the viscosity of the fluid that you choose to spray. Atomizing pressure and fluid viscosity directly relate to the efficiency of the equipment operation and the quality of the results that you will achieve.

The available air volume and pressure at the air cap of the spray gun will meet the delivery of fluid coming out of the nozzle to create a fine mist called atomization. This mist travels directly to your work piece where it blends together to form a connected wet film. Achieving a smooth, level surface will depend on the proper relationship between available atomizing pressure, the viscosity of the coating being applied and the properties of the coating.

Apollo Turbine Models 725 and 825

Model 725



Model 725

Hi Power 2-Stage Turbine

4.5 psi (0.31 bar)

112 cfm (3.17 cmm)

Dual air filtration

Single spray gun

110-120 volts, 60Hz, 10 amps, 1.5H.P.

220-240 volts, 50Hz, 5 amps, 1.5H.P.

Weight: 19lbs (8.6kg)

Height: 11" (27.94cm)

Width: 7.25" (18.41cm)

Length: 11.25" (28.58cm)

All EU units shipped 

All 110 volt units are tested and certified. 

Model 825

3-Stage Turbine

5.5 psi (0.38 bar)

115 cfm (3.25 cmm)

Dual air filtration

Single gun

110-120 volts, 60Hz, 11 amps, 1.65H.P.

220-240 volts, 50Hz, 5.5 amps, 1.65H.P.

Weight: 29lbs (13.2kg)

Height: 12" (30.48cm)

Width: 8.5" (21.6cm)

Length: 15" (38.1cm)

All EU units shipped

All 110 volt units are tested and certified.

Model 825



Model 1025

4-Stage Turbine

8.0 psi (0.55 bar)
 130 cfm (3.68 cmm)
 Dual air filtration
 Single spray gun
 110-120 volts, 60Hz, 13 amps,
 1.85H.P.
 220-240 volts, 50Hz, 6 amps,
 1.75H.P.

Weight: 30lbs (13.6kg)
Height: 12" (30.48cm)
Width: 8.5" (21.6cm)
Length: 15" (38.1cm)

All EU units shipped



All 110 volt units are
 tested and certified.



Model1025



APOLLO TURBINE MODEL 1040VR

The all NEW model 1040VR is the first in the line of the new Precision Series by Apollo Sprayers International, Inc. Apollo's Precision Air Control Technology (PACT) allows you to control the air pressure from the turbine to within 1/10th of a PSI. The 1040VR comes supplied with one spray gun and hose. The unit has the capability to run two spray guns using the optional "Y" connector (Part #A4227).

There is a single switch located on the front of the 1040VR turbine. This switch can be used in the "Variable Pressure" or UP position to operate the variable speed and LCD pressure display screen. The switch can also be used in the "Fixed Pressure" or DOWN position to bypass the control board and run the motor at 100% full power.

To control the air pressure on the 1040VR turbine, connect the spray gun and hose with the turbine. Plug the turbine into the appropriate voltage for your model. Move the switch to the UP or "Variable Pressure" setting. The factory has preset your turbine speed at the maximum speed. To get an accurate pressure reading it is advised that you let the turbine warm up for about 5 minutes. Once the turbine motor is warm the LCD will give you an accurate pressure reading.

The control board will automatically adjust the motor speed to compensate for barometric pressure and elevation. The pressure reading will always be accurate. To decrease the pressure from the maximum setting simply turn the knob underneath the LCD pressure display counter-clockwise.

To increase the pressure once reduced, turn the knob clockwise. As you turn the knob, the pressure will increase or decrease accordingly.

Model1040VR



4-Stage Turbine

8.0 psi (0.55 bar)
 130 cfm (3.68 cmm)
 Dual air filtration
 Single spray gun
 110-120 volts, 60Hz, 13 amps,
 1.85H.P.
 220-240 volts, 50Hz, 6 amps,
 1.75H.P.

Weight: 30lbs (13.6kg)
Height: 12" (30.48cm)
Width: 8.5" (21.6cm)
Length: 15" (38.1cm)

All EU units shipped



All 110 volt units are
 tested and certified.



The viscosity of the coating you want to spray will determine the amount of pressure needed. The thicker your viscosity is, the more pressure you will need to nicely atomize your coating. For highest efficiency, use the lowest pressure that produces the best atomization and finish results. If you experience "Orange Peel" you should increase the pressure. If you have too much overspray, you should decrease the pressure.

The 1040VR also has a filter warning system. The filter warning system works in conjunction with the Variable Pressure switch in the ON or UP position. This will prevent overheating your motor. To prevent damage to the motor the warning light will first turn from **GREEN** to **RED**.

NOTE: If the warning light is ignored and the motor is still used without changing or replacing the filters the turbine will turn off automatically. The system cannot be turned back on until the temperature of the motor cools down dramatically. If this happens, immediately check both the filters and pre-filters for a blockage. Once the filters have been cleaned or replaced and the motor has cooled down the turbine will reset itself. Once the turbine has reset it is safe to use again. **DO NOT** use "Fixed Pressure" setting to override the control board, this will cause damage to your motor and void your warranty. If the turbine has shut down, clean the filters and let it sit, **DO NOT** ignore the light.

APOLLO TURBINE MODEL 800S and 1000S

Model 800S

Model 800S has one air hose outlet on the side of the unit and is designed to run one spray gun. This model **DOES NOT** have an internal air relief valve installed. To use a non-bleed style spray gun with this unit (Apollo Model # A7500) it is necessary to install Part #A7538 - External Air Relief Valve. Failure to install this part when using a non-bleed turbine spray gun can cause premature motor failure and will void all warranty.



800S 3-Stage Turbine

5.5 psi (0.38 bar)
 115 cfm (3.25 cmm)
 Dual air filtration
 Single spray gun
 110-120 volts, 60Hz, 11 amps, 1.65H.P.
 220-240 volts, 50Hz, 5.5 amps, 1.65H.P.
Weight: 29lbs (13.2kg)
Height: 12" (30.48cm)
Width: 8.5" (21.6cm)
Length: 15" (38.1cm)

All EU units shipped



All 110 volt units are tested and certified.



1000S 4-Stage Turbine

8.0 psi (0.55 bar)
 130 cfm (3.68 cmm)
 Dual air filtration
 Single spray gun
 110-120 volts, 60Hz, 13 amps, 1.85H.P.
 220-240 volts, 50Hz, 6 amps, 1.75H.P.
Weight: 30lbs (13.6kg)
Height: 12" (30.48cm)
Width: 8.5" (21.6cm)
Length: 15" (38.1cm)

All EU units shipped



All 110 volt units are tested and certified.



APOLLO TURBINE MODEL 900

Model 900 has two independent air outlets. This unit is supplied with one outlet capped. To use two spray guns at the same time, the cap needs to be removed and a quick disconnect coupler installed (part #A2070). When using only one spray gun, always be sure that one outlet is capped. This model DOES NOT have an internal air relief valve installed. To use a non-bleed style spray gun with this unit (Apollo Model A7500) it is necessary to install Part #A7538 - External Air Relief Valve. Failure to install this part when using a non-bleed turbine spray gun can cause premature motor failure and will void all warranty.

Hi Power **3-Stage Turbine**

6.0 psi (0.41 bar)

120 cfm (3.40 cmm)

Dual air filtration

Dual spray gun capability

110-120 volts, 60Hz, 12 amps,

1.75H.P.

220-240 volts, 50Hz, 6 amps, 1.75H.P.

Weight: 34lbs (15.4kg)

Height: 15" (38cm)

Width: 13" (33cm)

Length: 17" (43cm)

All EU units shipped



All 110 volt units are
tested and certified.



Model 900



TURBINE MODEL 1100 AND 1200

Model 1100 and 1200 have three independent air outlets on the back of the unit with the option of running one, two or three spray guns at the same time. The units come supplied with one outlet with a quick disconnect coupler and two outlets capped. It is necessary to uncap each extra outlet and attach a quick disconnect coupler (Part #A2070) when operating additional spray guns. Always be sure to cap any unused air outlet.

There are two switches on the model 1100 and three switches on the model 1200. Machine Off. All switches in Off position. Low Power, (3psi), Right Switch in On position. Medium Power, (6psi), Right Switch in Off position and Left Switch in On position. (Two cooling fans located behind the two rectangular filters in the front of the unit operate automatically). High Power, (10psi), Left and Right Switch in On position. (Both cooling fans operate automatically). The Model 1200 operates the same as the Model 1100, but adds a 2.5 gallon (10 litre) pressure pot, a platform for the pressure pot, plus an automatic fluid feed system. This gives the option of continuous production spraying. The Model 1200 contains a grounded outlet for the automatic fluid feed system, which is operated by the third switch (far left) on the unit. *See Using Pressure Pots for additional information.*

As a general guide, use low power for thin viscosity materials, medium power for slightly thicker coatings and high power for thicker/heavier viscosities. Refer to viscosity chart (D) or call Apollo technical support **888-900-4857** for further information.

Model 1100

Three Separate Power Levels:

Low: 3.5 psi (0.24 bar) 94 cfm (2.66 cmm)

Medium: 6.0 psi (0.41 bar) 120 cfm (3.40 cmm)

High: 10 psi (0.69 bar) 200 cfm (5.66 cmm)

Five Air Filters

Three spray gun capability

110-120 volts, 60 Hz, 17 amps, 2.6H.P.

220-240 volts, 50 Hz, 9 amps, 2.6H.P.

Weight: 60lbs (27.2kg)

Height: 17" (43cm)*

Width: 18" (46cm)

Length: 26" (66cm)

* Handle increases height.

All EU units shipped



All 110 volt units are tested and certified.



Model 1100



Model 1200

Three Separate Power Levels:

Low: 3.5 psi (0.24 bar) 94 cfm (2.66 cmm)

Medium: 6.0 psi (0.41) 120 cfm (3.40 cmm)

High: 10 psi (0.69 bar) 200 cfm (5.66 cmm)

Five Air Filters

Three spray gun capability

110-120 volts, 60 Hz, 17 amps, 2.6H.P.

220-240 volts, 50 Hz, 9 amps, 2.6H.P.

Weight: 89lbs (40.4kg)

Height: 42" (107cm)*

Width: 18" (46cm)

Length: 26" (66cm)

* Handle and pressure pot increase height.

All EU units shipped



All 110 volt units are tested and certified.



Model 1200



KNOW YOUR COATINGS

Coating Properties

Coatings are a blend of resins and additives to create a product that will provide a protective and beautifying surface to your work piece. Different resins have different properties. It is important to use the correct coating to achieve a desired result. Manufacturers of coatings can control the resin solids content, production viscosity, sheen, color, flow-out enhancement and other properties. Some products offer ways to adjust the coating properties such as speeding up or slowing down the drying time, adding catalysts to strengthen the molecular bond or adding flattening agents to lower the sheen. Manufacturers will often give some guidelines on how to thin their product for spray application. There are many different types of spray equipment in use. Coatings manufacturers cannot address all of them. It is important for the finisher to understand the spray equipment and to use common sense to arrive at the correct fluid viscosity to produce the best possible results with the selected coating and the equipment being used.

Your Choice of Coatings and Viscosity

Extremely thin, watery or light bodied fluids such as inks, aniline dyes and oil stains can generally be used straight from the can. RTS or Ready to Spray waterbased finishing products are formulated to be used straight from the can without thinning with a 3 stage or larger turbine. Most other coating products will need to be thinned anywhere from 10% to 50% depending on the available air pressure of the turbine model and the properties of the coating selected. (see chart below).

CHART A TURBINE PERFORMANCE

TURBINE SIZE	UNRESTRICTED PRESSURE	COATING TYPES
2 STAGE	4.5PSI	Light Viscosity Materials Only
3 STAGE	5.5PSI	Light-Medium Viscosity Materials
4 STAGE	8.0PSI	Light-Heavy Viscosity Materials
Dual Turbine	10PSI (At full power)	Light - Heavy Viscosity Materials

USING LATEX (EMULSION) PAINT

Although your turbine spray system is best suited to spray Class A Finish coatings such as lacquers, enamels, urethanes, varnishes, waterborne and waterbase etc., you can spray latex (emulsion) house paint if you follow a few simple rules. First, it is absolutely necessary to thin latex (emulsion) paint. This will vary from as little as 10% to as much as 50%. This will depend on the model turbine you are using and the quality of the paint used. In addition, it is necessary to use a larger nozzle and needle set in the spray gun (2.0mm or 2.5mm). It is recommended that a latex (emulsion) paint conditioner, Floetrol®, be added to aid flow-out. This product is sold at local paint stores.

CHART B NOZZLE, NEEDLE AND AIR CAPS FOR 5000 SERIES SPRAY GUNS

TIP/NEEDLE SIZE	APPLICATION	AIR CAP
.75MM (.0295)(#1)	Inks, Dyes, Stains, extremely thin viscosity fluids, Water based finishes	(A) #A5201
1.0MM (.039) (#2)	All purpose, thin lacquers, thin enamels, Water based finishes, Automotive, Marine, Airplane finish	(A) #A5201
1.5MM (.059) (#3)	Catalyzed lacquers, Conversion Varnish, Primers, Automotive, Marine, Airplane, finish Varnish, High Viscosity Industrial Coatings, Urethanes, Enamel	(A) or (B) #A5201 #A5297
2.0MM (.079) (#4)	Thinned latex paint, Multi-spec, Heavy Primers, Butyrate, nitrate dope, High Viscosity Industrial Coatings	(B) #A5297
2.5MM (.098) (#5)	Thinned latex paint, Multi-spec, Solvent adhesives, Wax based strippers	(B) #A5297

**CHART C
NOZZLE, NEEDLE AND AIR CAPS FOR 7500 SERIES SPRAY GUNS**

TIP/NEEDLE SIZE	APPLICATION	AIR CAP
0.8MM (.029)	Inks, Dyes, Stains, extremely thin viscosity fluids, Water based finishes	A
1.0MM (.039)	All purpose, thin lacquers, thin enamels, Water based finishes, Automotive, Marine, Airplane finishes	B
1.3MM (.051)	All purpose, thin lacquers, thin enamels, Water based finishes, Automotive, Marine, Airplane finishes	B
1.5MM (.059)	Catalyzed lacquers, Conversion Varnish, Primers, Automotive, Marine, Airplane finishes, Varnish, High Viscosity Industrial Coatings, Urethanes, Enamel	B OR C
1.8MM (.070)	Catalyzed lacquers, Conversion Varnish, Primers, Automotive, Marine, Airplane finishes, Varnish, High Viscosity Industrial Coatings, Urethanes, Enamel	C
2.0MM (.079)	Thinned Latex (Emulsion) Paint, Multi-spec, Heavy Primers, Butyrate, Nitrate Dope, High Viscosity Industrial Coatings	C
2.5MM (.098)	Thinned Latex (Emulsion) Paint, Multi-spec, Solvent adhesives, Wax based strippers	D

CHART D -VISCOSITY

Coating	Thin/Reduce
Lacquers	25%-50%
Sanding Sealer	20%-30%
Enamels	20%-40%
Stains	use from can
Acrylic Enamel	50%-60%
Catalyzed Polyurethane	10%-30%
Polyurethane's Varnishes	20%-30%
Waterborne Coatings	00%-10%
Latex/Emulsion Paint	10%- 40%

Chart D should be used as a guide to thinning various coatings. Actual reduction will depend upon model turbine used, flow out properties of the coating and the final visual results of the sprayed work piece.

TECHNIQUE

Like any skill, practice makes perfect. Never try to rush the spray finishing process. Learn the characteristics of the coating you will be spraying. Build up layers of material (3-4 applications or more if necessary). Sand between coats and allow proper drying time between applications. Some rules for effective spray finishing:

1. Remember to always keep the distance between the spray gun and the surface the same when moving across your work, (or up and down) called a "pass". Do not rotate or turn your wrist from side to side.
See Chart E Below
2. Move the spray gun across your work from end to end.
3. Be sure to maintain the same speed of movement. This ensures an even application of coating.
4. At the end of a "pass" always release the trigger. To continue, spray in the opposite direction and overlap your previous coat by 1/3 to 1/2.
5. When finished you should have an even wet coat on your work. If you have dry spots you have overlapped too wide. If you have heavy or wet spots, you have overlapped too much or sprayed too slowly.
6. When spraying a large or pre-assembled piece, start at the top and work down.
7. Try to spray the hard to reach and underneath surfaces first.

Common sense and some forethought will prevent errors. Remember, that a light wet film will generally produce better results than a heavy wet coat. When spraying a vertical surface it is advisable to apply a thin/light "tack" coat first, followed by a normal light wet coat. This technique will help prevent "runs" and "sags".

CHART E SPRAY GUN TECHNIQUE

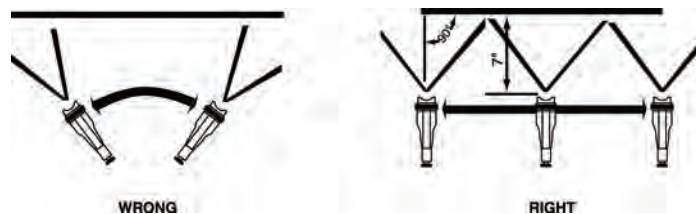

When using your Spray Gun you control five variables:

1. Fluid flow
2. Distance of the spray gun from your work. (4"-8" (10-20cm) is average. Closer if necessary).
3. Pattern direction (vertical fan, horizontal fan and round)
4. Speed of application
5. Fan pattern size. 7500 series with Fan Pattern Control Ring.
5000 series move the spray gun closer to or further away

NOTE: Items 1,2, and 4 directly relate to each other.

CLEANING YOUR TrueHVLP™ SPRAY GUN

Refer to your spray gun manual for cleaning and maintenance of your spray gun model.

USING PRESSURE POTS WITH TURBINE SYSTEMS

When using a remote cup or pressure pot, it is necessary to introduce compressed air in order to pressurize the remote pot and move the fluid from the pot to the tip/nozzle of the spray gun. In general 5lbs (2.26kilos) of pressure is sufficient for most average viscosity fluids in order to deliver the proper flow of fluid to the tip. Higher pressure would only be necessary for a heavier viscosity fluid. A good test to determine the correct fluid delivery would be to first pressurize the pot. **DO NOT** turn on the turbine. Pull the trigger of the spray gun until a stream of fluid flows from the tip/nozzle. Adjust the pressure until the fluid drops off or bends at approximately 2 1/2 " (6.35cm). Pot pressure should be correct at this point.

Part #A4600 - 2 quart (2 litre) pressure pot.

Part #A4900 - 2.5 gallon (10 litre) deluxe pressure pot.

▲ CAUTION

SAFETY PRECAUTION:

Always depressurize the remote pot using the safety valve when the equipment will be idle for a while.

This will prevent excess fluid from remaining in the fluid hose, and prevent a possible accident should the trigger be pulled and paint streams from the spray gun.

Always ensure that the remote cup is tightly sealed, and all gaskets are in good shape, to prevent air and fluid leaks. Be sure to flush and clean fluid hose at the end of a work session.

For smaller jobs, insert a one gallon can inside the 2.5 gal (10 litres) pressure pot. This will help to keep the inside of the pot clean.



NOTE: It may be necessary with some paint cans to remove the filter on the bottom of the pickup tube to allow for the clearance at the bottom of the pressure pot.

RECORD OF TURBINE USE

RECORD OF TURBINE USE		
MODEL	SERIAL #	DATE PURCHASED
DATE	HOURS OF USE	TOTAL HOURS

Turbine Recommended Maintenance: Clean and/or change pre-filters and/or cartridge filters every 50 hours or when necessary. See Accessories Page for appropriate filter replacement for your model.

RECORD OF TURBINE MAINTENANCE	
DATE	MAINTENANCE PERFORMED

TURBINE MAINTENANCE AND CLEANING

CAUTION

Always unplug your turbine from the main electrical supply before doing any maintenance or repairs.

After Each Use:

Your Apollo turbine system requires very little maintenance. The turbine motor has sealed bearings that are lubricated for life.

The only maintenance that you will need to perform is checking, cleaning and replacing your filters and pre-filters as required. It is very important that your motor has cool, clean air to operate efficiently. If you maintain your filters and pre-filters well, you will enjoy many years of long service from your turbine motor.

CAUTION

Always use genuine Apollo filters and pre-filters. Other types of filters and pre-filters may prevent proper air flow to the motor, resulting in premature motor failure and voiding your warranty.

Pre-Filter Maintenance

We recommend that you remove your pre-filters after each use. To remove the pre-filters: simply push your finger between the filter and the pre-filter until you can curl it up and pull the pre-filter off, rotating your finger around the pre-filter as you pull. Do not pull hard as you will break the glue line on the pre-filter. Make sure you check both pre-filters as they can get dirty at different intervals. If they appear to be a little dirty or clogged, you can wash them out using a mild soap and warm water. If they are not cleanable you need to install new pre-filters.

To reinstall the pre-filters hold one in both hands and apply the top first, moving your fingers around the inside as you slide it back over the filter cartridge from top to bottom. **NEVER** operate your turbine without both filters and pre-filters installed and clean.



Filter Maintenance

We recommend that you visually check your filter when you remove your pre-filters for cleaning. Check for accumulated material in the filter element. If you suspect they may be dirty, or if you can see material building up, don't take a chance, remove the filter and hold it up into the light.

To remove your filters, first remove the filter plate by unscrewing the two dome nuts on each side. Once you have removed the dome nuts the filter plate should slide off, sometimes it can hang up on the threads so make sure you pull it off straight. Once the filter plate is removed, the filter and pre-filter will come off together. If they are stuck to the side of the case, gently tap them downward with your hand.

To check your filters hold them up to a light, similar to your car air intake filter. If you can see light through more than 50% of the filter as you turn it, you do not need to replace them. If you cannot see light through more than 50% of the filter, you must replace your filter element.

If they appear to be dirty you can tap them on a flat surface, gently, to remove any debris. If you have compressed air available, you can also blow them off with air. If you use compressed air to clean your filters, make sure you blow the air from the inside out and never use more than 50PSI or this will damage the filter element.

To reinstall the filters, reverse the instructions above. Make sure that you line the filter up with the filter plate first, this will help to keep it straight when replacing the dome nuts.

For Models 800S and 900S

On "S" Models, remove the two hex-head securing nuts in order to remove the filters for cleaning or replacement. Periodically wash and blow excess dust and dirt with water and an air compressor. Dirty filters will reduce the air being drawn through the motor, causing the unit to run abnormally hot, diminish spray performance, and reduce the life of the motor. Clean and/or replace filters when you suspect they can no longer be cleaned. Use the maintenance record sheet on Page 15 to keep track of your equipment use.

Annual Maintenance:

We recommend that you check the carbon brushes at least once a year or every 300 hours, which ever comes first. To check your carbon brushes consult with an authorized Apollo repair facility.

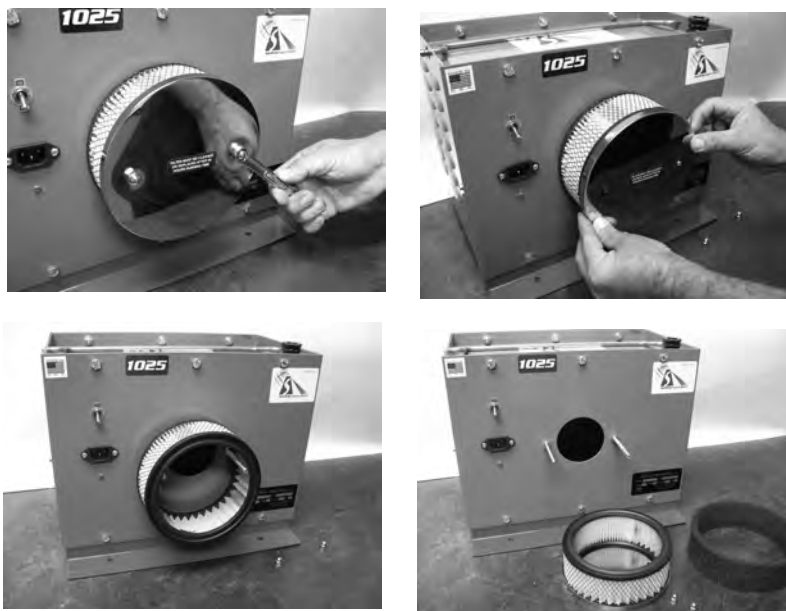

Model 725

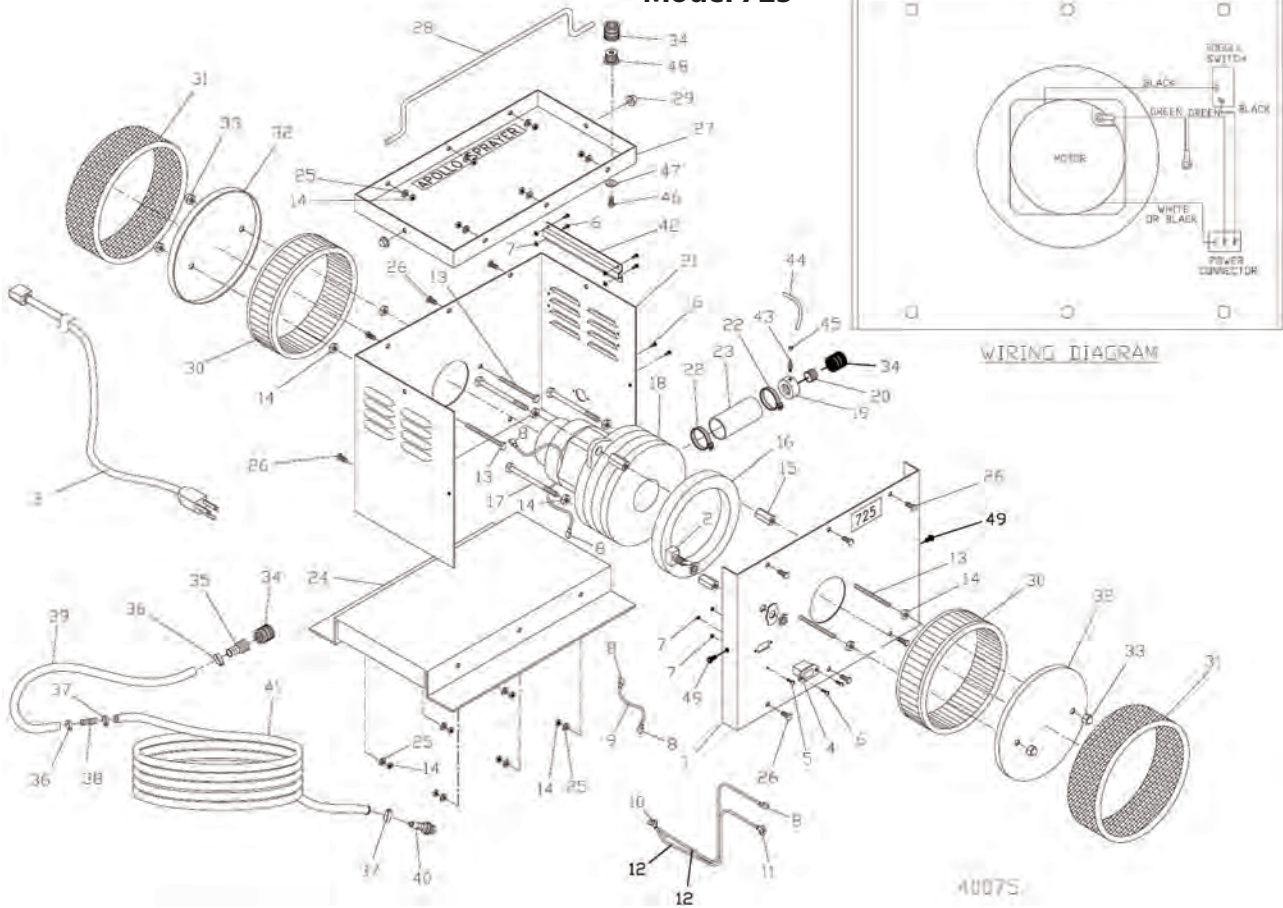

Model 725 Turbine Parts List January 1, 2008

Diagram #	Part #	Description	Quantity	Diagram#	Part #	Description	Quantity
1	A4710	Front plate	1	26	A4320	1/4" x 20 x 1/2" Hex Bolt, plated	14
2	A4029	Switch & Plate	1	27	A4712	Case top	1
3	A4028	Power cord 8'	1	28	A4751	Carrying handle	1
4	TC1038	IEC320 male computer plug	1	29	A4345	5/16" handle cap	2
5	A4318	Ground Screw	1	30	A4057	Filter element, 6 x 1.5" round	2
6	A4318	6-32 x 1/2" phill pan m/s plated	10	31	A4191	Pre-filter 3/8" x 1 1/2" x 19"	2
7	A4307	6-32 Hex M/S nuts, plated	6	32	A4181	Round filter plate	2
8	A4179	Wire terminal	5	33	A4310	1/4" x 20 cap nut plated	4
9	A4991	6" piece of Black wire, 14 AWG	1	42	A4857	Vent Manifold	1
10	A4178	Ground terminal - Large Eye	1	43	A2118	1/4" NPT X 1/4" Male hose barb.	1
11	A4180	Ground terminal - Small Eye Connector	1	44	A5415	Bleed hose 12"	1
12	A4999	6" piece of grounding wire, 14 AWG	1	45	A5414	Hose clamp	1
13	A4366	1/4" x 20 x 1 3/4" hex head tap bolt, plated	4	46	A4367	Handi-Hold mounting bolt	1
14	A4308	1/4" x 20 Hex Nuts	21	47	A4302	Handi-Hold mounting washer	1
15	A4349	1/4" x 20 length 7/8 hex	3	48	A5416	Handi-Hold mounting block	1
16	A4176	Spliced rubber gasket	1	49	A4315	#8 x 1/2" HVH sheet metal screw	2
17	A4373	1/4 x 20 x 2 1/2" half thread hex head bolt, plated	3	Hose Fittings			
18	A4161	2 stage, 5.7" tangential motor	1	34	A2070B	Black quick connect, female	3
19	A7537	Female Bleed Adapter	1	35	ST2163	5/8" black hose adapter (3/4" male)	1
20	A4756	Male Turbine adapter	1	36	A2089	S.S. hose clip 15/16" O.D.	2
21	A4711	Housing/cover	1	37	A2168	S.S. hose clip 7/8" O.D.	2
22	A4177	Hose clamp size 28-1/2"	2	38	A2155	5/8" brass air hose joiner	1
23	A4222	Rubber hose, turbine exhaust	1	39	A2157	4 feet of flex hose, per foot	4
24	A4708	Base	1	40	ST2111B	5/8" alloy air hose adapter (male)	1
25	A4300	1/4" SAE Flat Washer, plated	14	41	A2167B	10 feet of air hose, per foot	10

Model 825

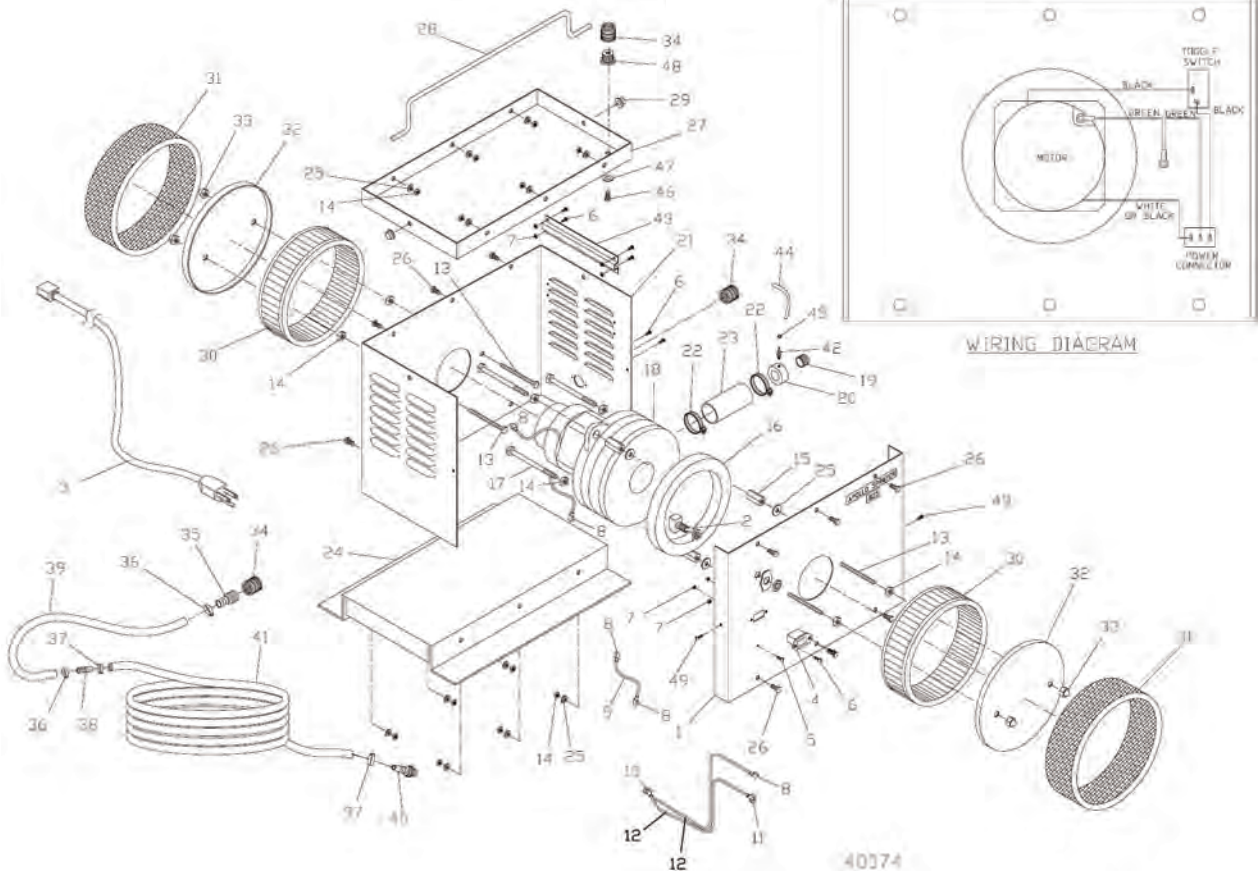

825 Turbine Parts List January 1, 2008

Diagram #	Part #	Description	Quantity
1	A4814	Front plate	1
2	A4029	Switch & Plate	1
3	A4028	Power cord 8'	1
4	TC1038	IEC 320 male computer plug	1
5	A4318	Green grounding screw	1
6	A4318	6-32 x 1/2" phill pan m/s plated	8
7	A4307	6-32 Hex M/S nuts, plated	3
8	A4179	Wire terminal	5
9	A4991	6" piece of Black wire, 14 AWG	1
10	A4178	Ground terminal - Large Eye	1
11	A4180	Ground terminal - Small Eye Connector	1
12	A4999	6" piece of grounding wire, 14 AWG	1
13	A4350	1/4" x 20 x 2 3/4" full thread hex	4
14	A4308	1/4" x 20 Hex Nuts	19
15	A4349	1/4" x 20 length 7/8 hex	3
16	A4176	Spliced rubber gasket	1
17	A4371	Bolt 1/4 x 20 x 3 1/4 half thread hex	3
18	A4163	3 stage, 5.7" tangential motor	1
19	A4756	Male Turbine adapter	1
20	A7537	Female air bleed Adapter	1
21	A4815	Housing/cover	1
22	A4177	Hose clamp size 28-1/2"	2
23	A4222	Rubber hose, turbine exhaust	1
24	A4806	Base	1
25	A4300	1/4" SAE Flat Washer, plated	12

Diagram #	Part #	Description	Quantity
26	A4320	1/4" x 20 x 1/2" Hex Bolt, plated	12
27	A4817	Case top	1
28	A4139	Carrying handle	1
29	A4345	5/16" handle cap	2
30	A4169	Filter element, 6 x 2 round	2
31	A4190	Pre-filter 3/8" x 2 1/4" x 19"	2
32	A4181	Round filter plate	2
33	A4310	1/4" x 20 cap nut plated	4
34	A2070B	Female Quick Connector	3
42	A2118	1/4" NPT X 1/4" Male hose barb.	1
43	A4857	Vent Manifold	1
44	A5415	Bleed hose 12"	1
45	A5414	Hose clamp	1
46	A4367	Handi-Hold mounting bolt	1
47	A4302	Handi-Hold mounting washer	1
48	A5416	Handi-Hold mounting block	1
49	A4315	#8 X 3/8" HWH sheet metal screw	2
Hose Fittings			
35	ST2163	5/8" black hose adapter (3/4" male)	1
36	A2069	S.S. hose clip 15/16" O.D.	2
37	A2168	S.S. hose clip 7/8" O.D.	2
38	A2155	5/8" brass air hose joiner	1
39	A2157	4 feet of flex hose, per foot	4
40	ST2111B	5/8" alloy air hose adapter (male)	1
41	A2167B	20 feet of air hose, per foot	20

Model 900

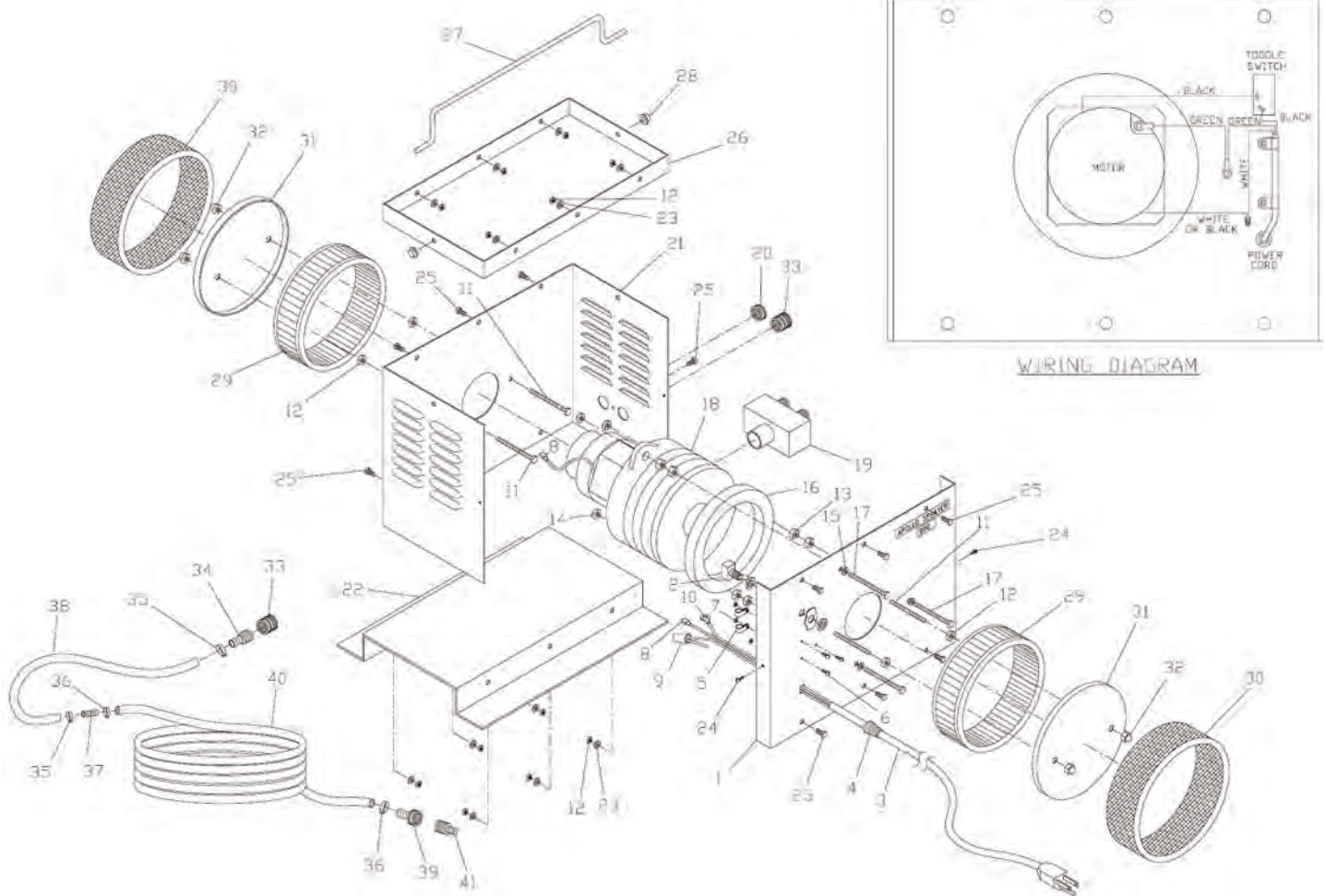

Model 900 Turbine Parts List January 1, 2008

Diagram #	Part #	Description	Quantity	Diagram #	Part #	Description	Quantity
1	A4804	Front plate	1	22	A4806	Base	1
2	A4029	Switch & Plate	1	23	A4300	1/4" SAE Flat Washer, plated	12
3	A4028	Power cord 8'	1	24	A4315	#8 x 3/8" HWH sheet metal screw	2
4	A4053	Cable grommet	1	25	A4320	1/4" x 20 x 1/2" Hex Bolt, plated	13
5	A4051	Cable clamp	2	26	A4807	Top	1
6	A4318	6-32 x 1/2" phill pan m/s plated	3	27	A4139	Carrying handle	1
7	A4307	6-32 Hex M/S nuts, plated	3	28	A4345	5/16" handle cap	2
8	A4179	Insulated wire terminal	2	29	A4169	Filter element, 6 x 2 round	2
9	A4192	Twist on wire connector	1	30	A4190	Pre-filter 3/8" x 2 1/4" x 19"	2
10	A4178	Ground terminal - Large	1	31	A4181	Round filter plate	2
11	A4350	1/4" x 20 x 2 3/4" full thread hex	4	32	A4310	1/4" x 20 cap nut plated	4
12	A4308	1/4" x 20 Hex Nuts	16	33	A2070	Female Quick Connector	2
13	A4357	5/16" X 18 nut, plated	6	Hose Fittings			
14	A4314	5/16" X 18 nylon lock nut plated	3	34	A2163	5/8" brass hose adapter (male)	1
15	A4302	5/16" washer	3	35	A2069	S.S. hose clip 15/16" O.D.	2
16	A4070	Spliced rubber gasket	1	36	A2168	S.S. hose clip 7/8" O.D.	2
17	A4356	Bolt 5/16 X 18 X 4 1/2 full thread hex	3	37	A2155	5/8" brass air hose joiner	1
18	A4162	3-Stage 7.2" Diameter motor/turbine	1	38	A2157	4 feet of flex hose, per foot	4
19	A4143	Manifold	1	39	A2110	5/8" brass swivel air hose adapter (female)	1
20	A2103	Outlet cap	1	40	A2167	30 feet of air hose, per foot	30
21	A4815SS	Housing/cover	1	41	A2111	Male quick connect	1

Model 1025

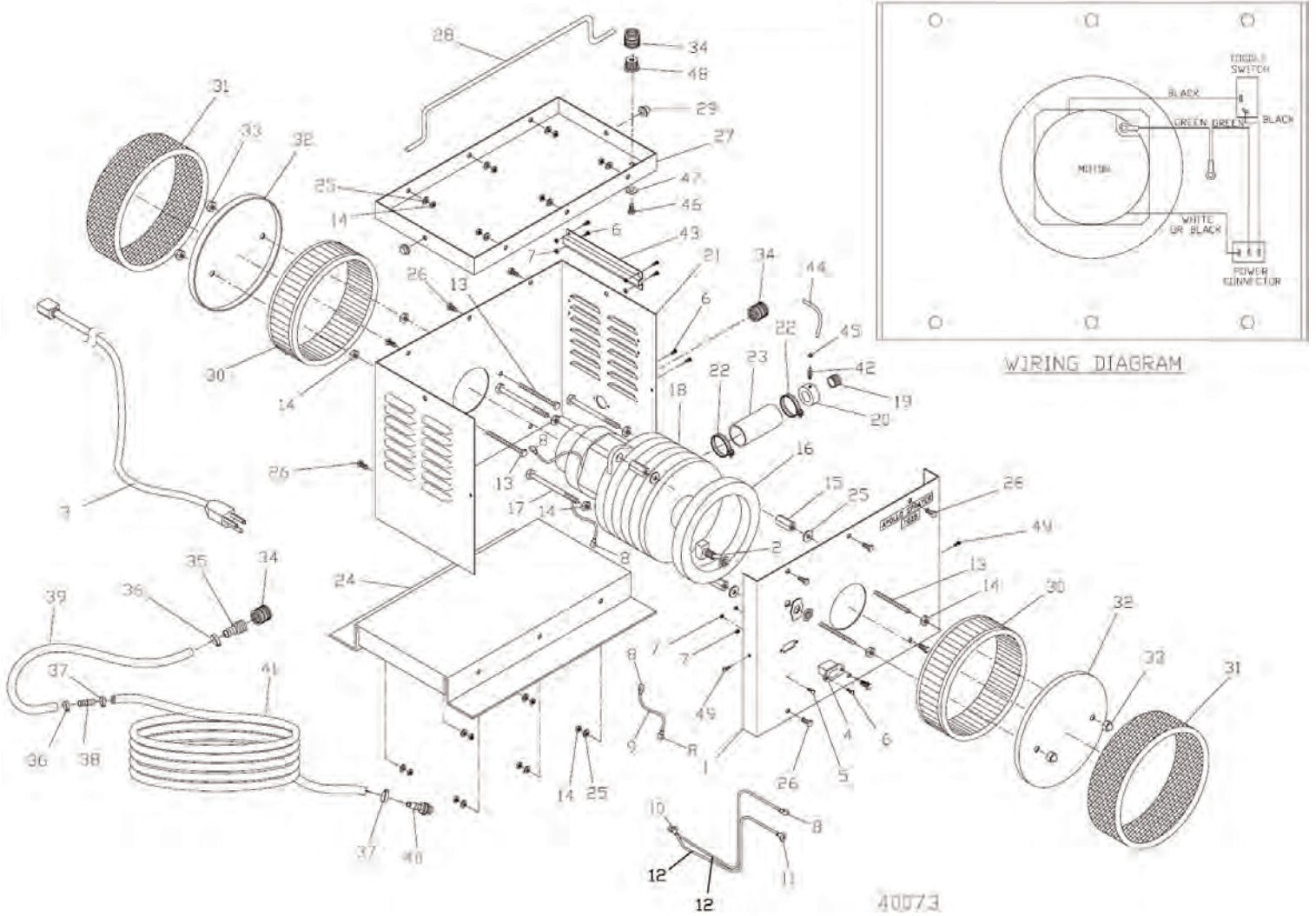

1025 Turbine Parts List January 1, 2008

Diagram #	Part #	Description	Quantity
1	A4814	Front plate	1
2	A4029	Switch & Plate	1
3	A4028	Power cord 8'	1
4	TC1038	IEC 320 male computer plug	1
5	A4318	Green grounding screw	1
6	A4318	6-32 x 1/2" phill pan m/s plated	11
7	A4307	6-32 Hex M/S nuts, plated	9
8	A4179	Wire terminal	2
9	A4991	6" piece of Black wire, 14 AWG	1
10	A4178	Ground terminal - Large Eye	1
11	A4180	Ground terminal - Small Eye Connector	1
12	A4999	6" piece of grounding wire, 14 AWG	2
13	A4350	1/4" x 20 x 2 3/4" full thread hex	4
14	A4308	1/4" x 20 Hex Nuts	19
15	A4349	1/4" x 20 length 7/8 hex	3
16	A4176	Spliced rubber gasket	1
17	A4371	Bolt 1/4 x 20 x 3 1/4 half thread hex	3
18	A4174	4 stage, 5.7" tangential motor	1
19	A4756	Male Turbine adapter	1
20	A7537	Female air bleed Adapter	1
21	A4815	Housing/cover	1
22	A4177	Hose clamp size 28-1/2"	2
23	A4222	Rubber hose, turbine exhaust	1
24	A4806	Base	1
25	A4300	1/4" SAE Flat Washer, plated	15
26	A4320	1/4" x 20 x 1/2" Hex Bolt, plated	12
27	A4817SS	Case top	1
28	A4139	Carrying handle	1
29	A4345	5/16" handle cap	2
30	A4169	Filter element, 6 x 2 round	2
31	A4190	Pre-filter 3/8" x 2 1/4" x 19"	2
32	A4181	Round filter plate	2
33	A4310	1/4" x 20 cap nut plated	4
34	A2070B	Female Quick Connector	3
42	A2118	1/4" NPT X 1/4" Male hose barb.	1
43	A4857	Vent Manifold	1
44	A5415	Bleed hose 12"	1
45	A5414	Hose clamp	1
46	A4367	Handi-Hold mounting bolt	1
47	A4302	Handi-Hold mounting washer	1
48	A5416	Handi-Hold mounting block	1
49	A4315	#8 X 3/8" HWH sheet metal screw	2
Hose Fittings			
35	ST2163	5/8" black alloy hose adapter (male)	1
36	A2069	S.S. hose clip 15/16" O.D.	2
37	A2168	S.S. hose clip 7/8" O.D.	2
38	A2155	5/8" brass air hose joiner	1
39	A2157	4 feet of flex hose, per foot	4
40	A2111B	5/8" black alloy air hose adapter (male)	1
41	A2167	20 feet of air hose, per foot	20

1100 Model Chassis

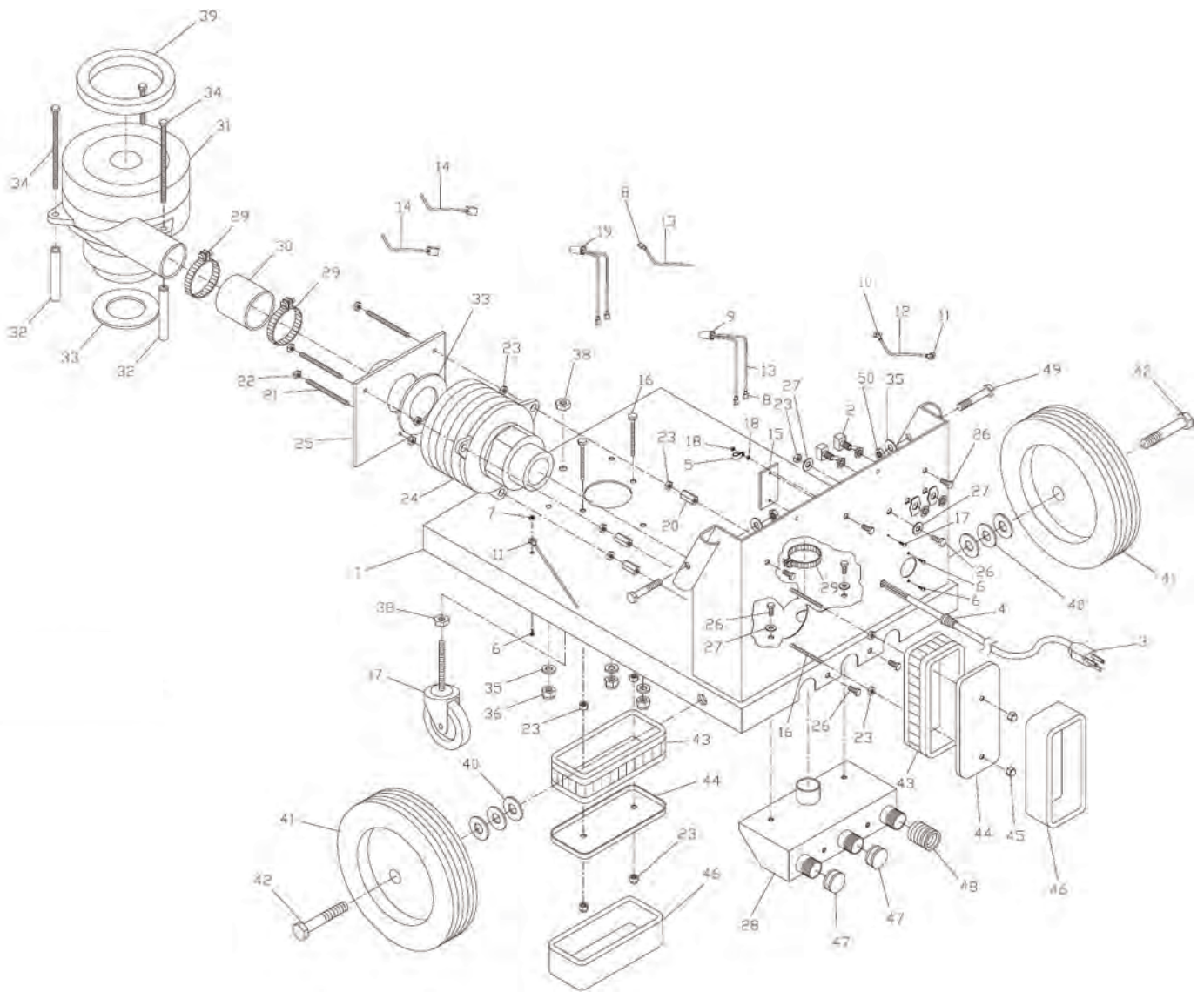

1100 Model Turbine

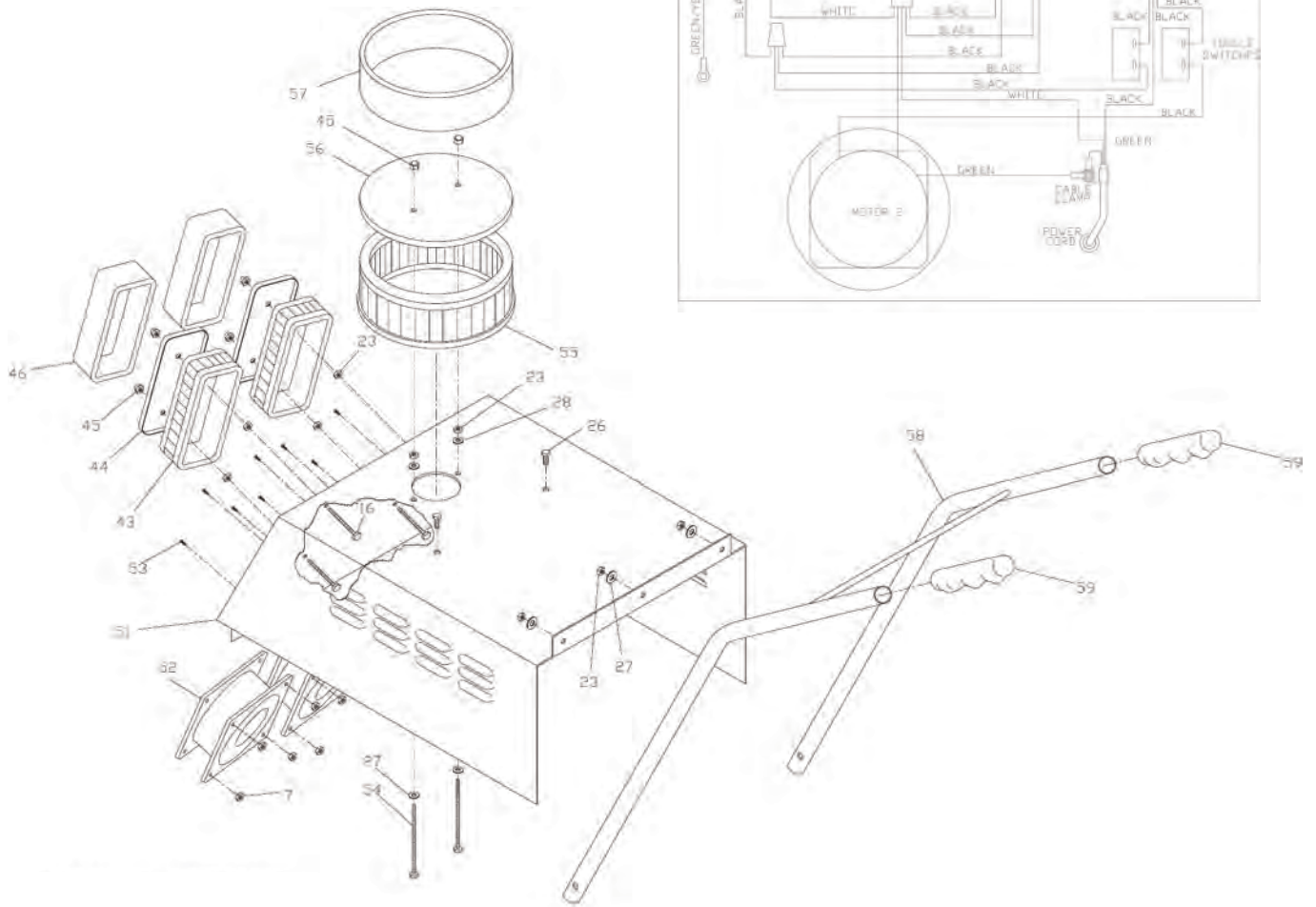

1100 Model Airhose

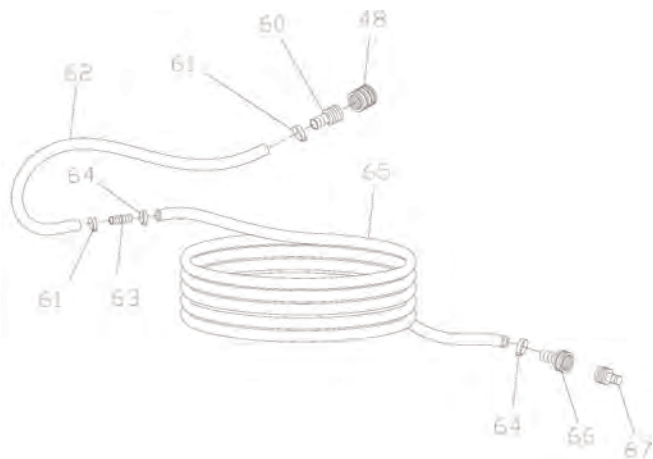

Model 1100 Turbine Parts List

January 1, 2008

Diagram #	Part #	Description	Quantity
1	A4085	Chassiss for model 1100/1200	1
2	A4029	Switch & Plate	2
3	A4028	Power cord 8'	1
4	A4195	Cable Gromet, Large	1
5	A4051	Cable clamp	1
6	A4318	6-32 x 1/2" phill pan m/s plated	3
7	A4307	6-32 Hex M/S nuts, plated	11
8	A4179	Insulated Wire Terminal	4
9	A4194	Wire Connector, Yellow	2
10	A4178	Large ring terminal	1
11	A4180	Small ring terminal	1
12	A4999	6" piece of Green wire, 14 AWG	1
13	A4991	6" piece of Black wire, 14 AWG	1
14	A4990	Fan Cord	2
15	A4197	Outlet plate	1
16	A4332	1/4" X 20 X 3" hex hd. tap bolt	4
17	A4336	5/8" 10-32 Phil. Head, Green	1
18	A4362	Hex nut 10-32 plated	2
19	A4193	Twist-on wire connectors, red	1
20	A4349	1/4" x 20 length 7/8 hex	3
21	A4361	Threaded rod 1/4 X 20 X 6.25" lengths	3
22	A4309	1/4" x 20 nylon lock nut plated	3
23	A4308	1/4" x 20 Hex Nuts	25
24	A4164	2 stage 3.2 psi 5.7" tangential motor	1
25	A4102	Motor mount plate 1100 & 1200 Mk2	1
26	A4320	1/4" x 20 x 1/2" Hex Bolt, plated	13
27	A4300	1/4" SAE Flat Washer, plated	14
28	A4989	Manifold for 1100 & 1200	1
29	A4177	Hose clamp size 28-1/2"	3
30	A4250	Rubber hose, thin wall 2" dia 3" piece	1
31	A4162	Ametek Turbine Motor 6.0 PSI	1
32	A4090	Motor Support Tube 4.5" X .05/ft.	3
33	A4105	Transition tube Gasket	2
34	A4325	5/16" X 18 X 5.5" tap bolt plated	3
35	A4302	5/16" SAE F/W Plated Washer	5
36	A4314	5/16" X 18 nylon lock nut plated	3
37	A4173	Swivel wheel/castor	1
38	A4358	Nut 1/2 X 13 hex plated	2
39	A4070	Spliced rubber spacing gasket 1 X .5 X 5.75	1
40	A4305	1/2" SAE F/W plated washer	6
41	A4045	Wheel, 8" ball bearing/ rubber tire	2
42	A4360	Bolt 1/2 X 13 X 2" half thread hex. plated	2
43	A4098	6" X 4" 1 1/2" rectangle paper filter	4
44	A4094	6" X 4" rectangular Filter Plate	4
45	A4310	1/4" x 20 cap nut plated	8
46	A4190	Char-ether pre-filter 3/8" X 2 1/4" X 19"	4
47	A2103	Brass air cap, new style	2
48	A2070	Brass quick connect (female)	2
49	A4322	3/8" X 16 X 2" full thread plated hex bolt	2
50	A4313	3/8" X 16 plated nut	2
51	A4088	Cover for model 1100/1200	1
52	A4103	Fan	2
53	A4317	6-32 X 1/2" counter sunk head	8
54	A4333	1/4" X 20 X 4" full thread bolt	2
55	A4097	9" X 3" round paper element	1
56	A4196	9" round Filter Plate	1
57	A4095	Char-ether pre-filter 3/8" X 3 1/4" X 26"	1
58	A4006	Handle (Chrome)	1
59	A4042	Handle Grip (Plastic)	2
Air Hose Fittings			
60	A2163	5/8" brass hose adapter (male)	1
61	A2168	S.S. hose clip 7/8" O.D.	2
62	A2157	4 feet of flex hose, per foot	4
63	A2155	5/8" brass air hose joiner	1
64	A2069	S.S. hose clip 15/16" O.D.	2
65	A2167	40 feet of air hose, per foot	40
66	A2110	5/8" brass swivel air hose adapter (female)	1
67	A2111	Male quick connect	1

1200 Model Chassis

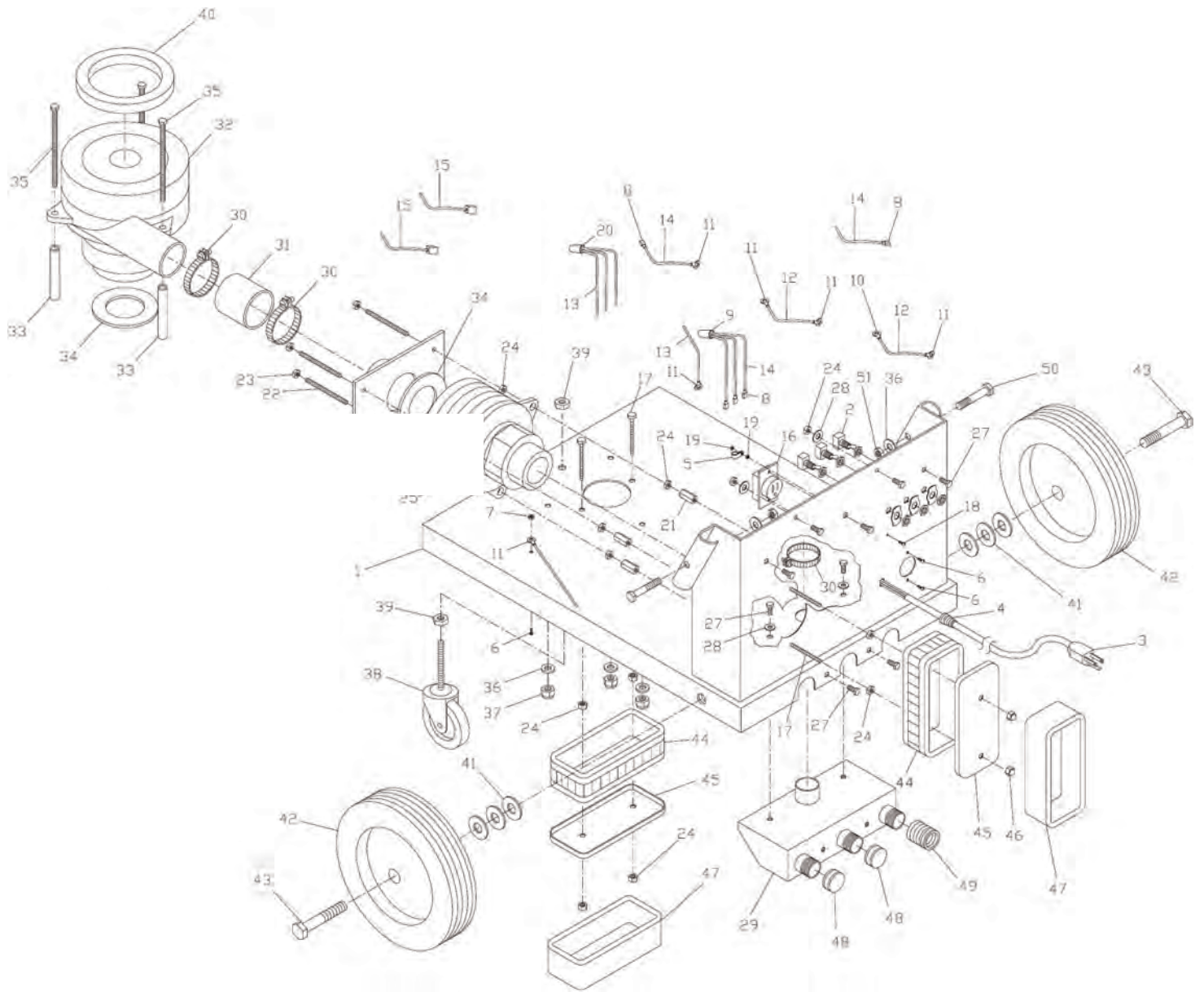

1200 Model Top

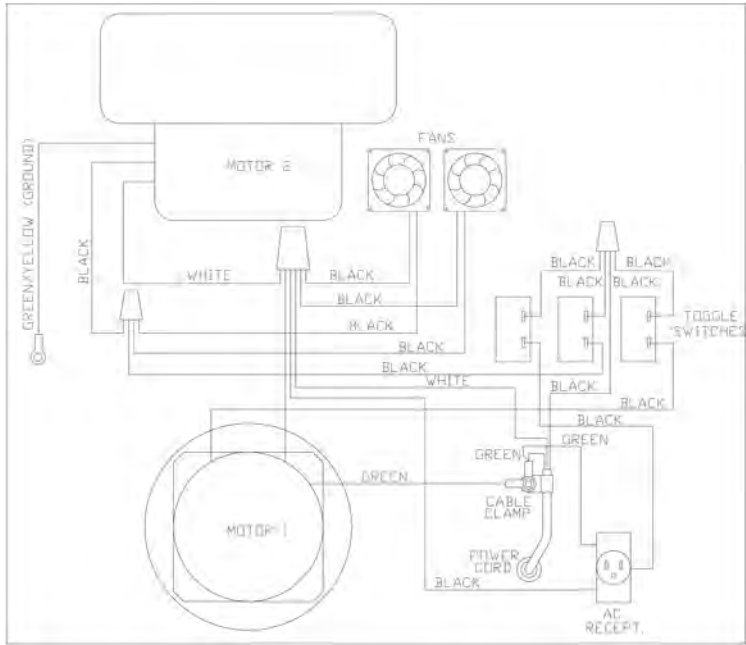
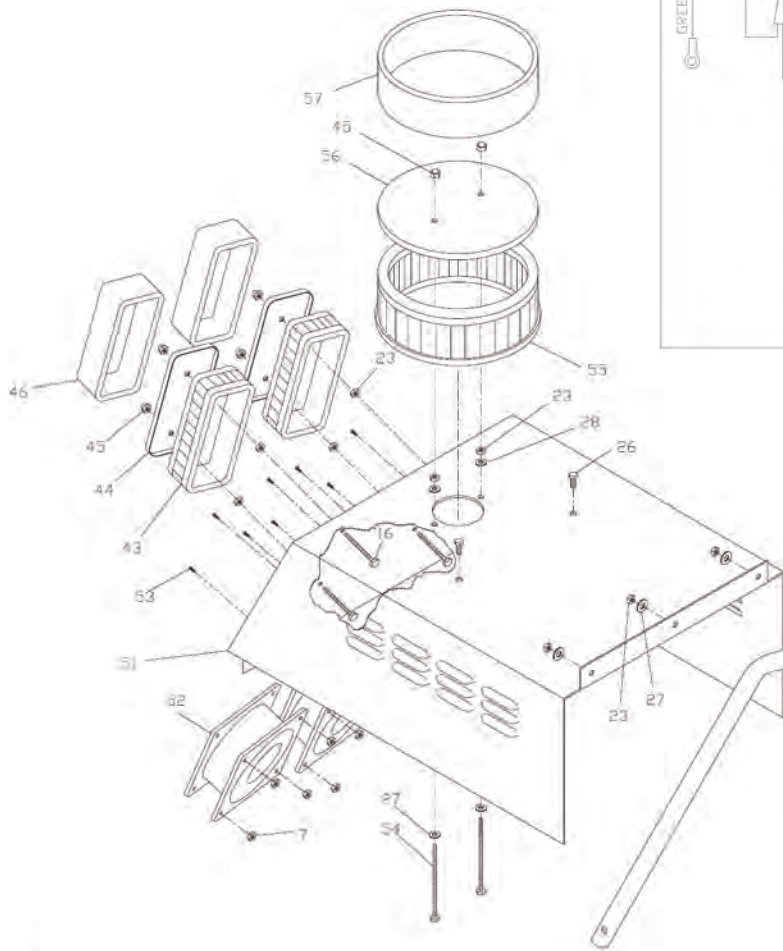

1200 Model Airhose

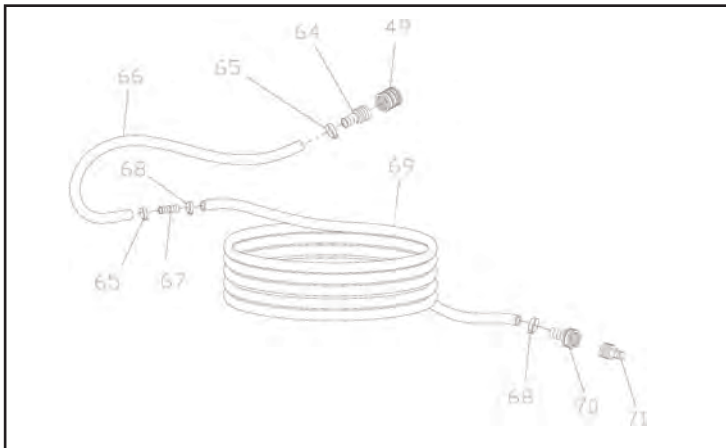

1200 Model Fluid Hose

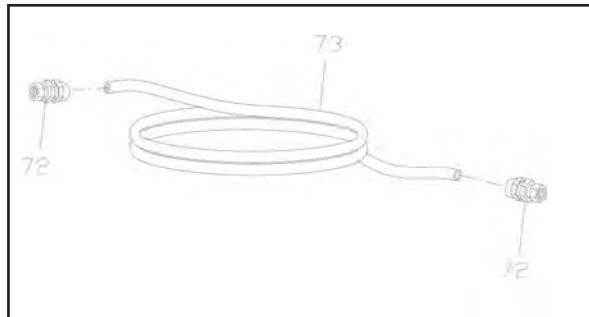

Model 1200 Turbine Parts List

January 1, 2008

Diagram #	Part #	Description	Quantity
1	A4085	Chassiss for model 1100/1200	1
2	A4029	Switch & Plate	3
3	A4028	Power cord 8'	1
4	A4195	Cable Gromet, Large	1
5	A4051	Cable clamp	1
6	A4318	6-32 x 1/2" phill pan m/s plated	3
7	A4307	6-32 Hex M/S nuts, plated	9
8	A4179	Wire Terminal	6
9	A4194	Wire Connector, Yellow	2
10	A4178	Ground terminal - Large Eye	1
11	A4180	Ground terminal - Small Eye Connector	6
12	A4999	6" piece of grounding wire, 14 AWG	2
13	A4992	6" piece of white copper wire, 14 AWG	1
14	A4991	6" piece of black copper wire, 14 AWG	1
15	A4990	Fan Cord	2
16	A4197	Grounding Outlet 15Amp-125 Volt	1
17	A4332	1/4" X 20 X 3" hex hd. tap bolt	4
18	A4336	5/8" 10-32 Phil. Head, Green	1
19	A4362	Hex nut 10-32 plated	2
20	A4193	Twist-on wire connectors, red	1
21	A4349	1/4" x 20 length 7/8 hex	3
22	A4361	Threaded rod 1/4 X 20 X 6.25" lengths	3
23	A4309	1/4" x 20 nylon lock nut plated	3
24	A4308	1/4" x 20 Hex Nuts	23
25	A4164	2 stage 3.2 psi 5.7" tangential motor	1
26	A4102	Motor mount plate 1100 & 1200 Mk2	1
27	A4320	1/4" x 20 x 1/2" Hex Bolt, plated	16
28	A4300	1/4" SAE Flat Washer, plated	11
29	A4989	Manifold for 1100 & 1200	1
30	A4177	Hose clamp size 28-1/2"	3
31	A4250	Rubber hose, thin wall 2" dia 3" piece	1
32	A4162	Ametek Turbine Motor 6.0 PSI	1
33	A4090	Motor Support Tube 4.5" X .05/ft.	3
34	A4105	Transition lube Gasket	2
35	A4325	5/16" X 18 X 5.5" tap bolt plated	3
36	A4302	5/16" SAE F/W Plated Washer	5
37	A4314	5/16" X 18 nylon lock nut plated	3
38	A4173	Swivel wheel/castor	1
39	A4358	Nut 1/2 X 13 hex plated	2
40	A4070	Spliced rubber spacing gasket 1 X .5 X 5.75	1
41	A4305	1/2" SAE F/W plated washer	6
42	A4045	Wheel, 8" ball bearing/ rubber tire	2
43	A4360	Bolt 1/2 X 13 X 2" half thread hex. plated	2
44	A4098	6" X 4" 1 1/2" rectangle paper filter	4
45	A4094	6" X 4" rectangular Filter Plate	4
46	A4310	1/4" x 20 cap nut plated	8
47	A4190	Char-ether pre-filter 3/8" X 2 1/4" X 19"	4
48	A2103	Brass air cap, new style	2
49	A2070	Brass quick connect (female)	2
50	A4322	3/8" X 16 X 2" full thread plated hex bolt	2
51	A4313	3/8" X 16 plated nut	2
52	A4088	Cover for model 1100/1200	1
53	A4103	Fan	2
54	A4317	6-32 X 1/2" counter sunk head	8
55	A4333	1/4" X 20 X 4" full thread bolt	2
56	A4097	9" X 3" round paper element	1
57	A4196	9" round filter plate	1
58	A4095	Char-ether pre-filter 3/8" X 3 1/4" X 26"	1
59	A4006	Handle (Chrome)	1
60	A4042	Handle Grip (Plastic)	2
61	A4112	Fluid Feed System	1
62	A4101	Pressure Pot Platform	1
63	A4015	2.5 Gallon Pressure Pot	1
Air Hose Fittings			
64	A2163	5/8" brass hose adapter (male)	1
65	A2168	S.S. hose clip 7/8" O.D.	2
66	A2157	4 feet of flex hose, per foot	4
67	A2155	5/8" brass air hose joiner	1
68	A2069	S.S. hose clip 15/16" O.D.	2
69	A2167	40 feet of air hose, per foot	30
70	A2110	5/8" brass swivel air hose adapter (female)	1
71	A2111	Male quick connect	1
Fluid Hose Fittings			
72	A2064	1/4" fluid connector	2
73	A2117	1/4" lined fluid hose, per foot	40

Model 1040VR

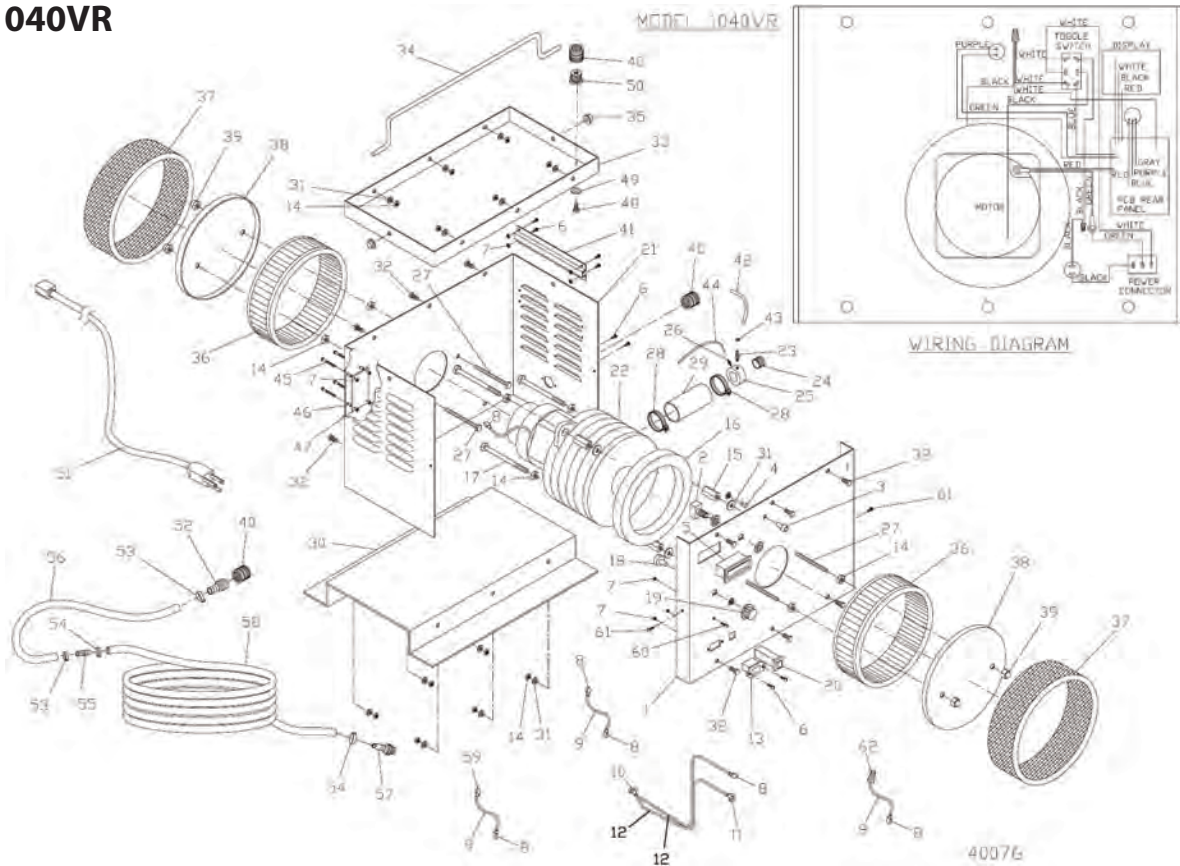

1040VR Turbine Parts List January 1, 2008

Diagram #	Part #	Description	Quantity	Diagram #	Part #	Description	Quantity
1	A4814	Front plate	1	33	A4817	Case top	1
2	A4029	Switch & Plate	1	34	A4139	Carrying handle	1
3	LEDHOLD	LED Holder	1	35	A4345	5/16" handle cap	2
4	160-1715-ND	LED	1	36	A4169	Filter element, 6 x 2 round	2
5	PM-128E	LCD Display	1	37	A4190	Pre-filter 3/8" x 2 1/4" x 19"	2
6	A4318	6-32 x 1/2" phill pan m/s plated	19	38	A4181	Round filter plate	2
7	A4307	6-32 Hex M/S nuts, plated	17	39	A4310	1/4" x 20 cap nut plated	4
8	A4179	Wire terminal	2	40	A2070B	Female Quick Connector	3
9	A4991	6" piece of Black wire, 14 AWG	1	41	A4857	Vent Manifold	1
10	A4178	Ground terminal - Large Eye	1	42	A5415	Bleed hose 12"	1
11	A4180	Ground terminal - Small Eye Connector	1	43	A5414	Hose clamp	1
12	A4999	6" piece of grounding wire, 14 AWG	1	44	A5299	Air tube - pressure sensor 16"	1
13	TC1038	IEC320 plug	1	45	A4379	6-32 x 3/4" Phill pan M/S plated	4
14	A4308	1/4" x 20 Hex Nuts	19	46	A5299	PCB Stand-off tubes	4
15	A4349	1/4" x 20 length 7/8 hex	3	47	PCB-110	PC control board	1
16	A4176	Spliced rubber gasket	1	48	A4367	Handi-Hold mounting bolt	1
17	A4371	Bolt 1/4 x 20 x 3 1/4 half thread hex	3	49	A4302	Handi-Hold mounting washer	1
18	31CN505	Speed control switch	1	50	A5416	Handi-Hold mounting block	1
19	45KN017	Speed control knob	1	51	A4028	Power cord 8'	1
20	A4997	12amp reset button	1	59	A4192	Crimp-on wire connector	1
21	A4815	Housing/cover	1	60	A4318	Green grounding screw	1
22	A4174	4 stage, 5.7" tangential motor	1	61	A4315	#8 X 3/8" HWH sheet metal screw	2
23	A2118	1/4" NPT X 1/4" Male hose barb	1	62	A4194	Wire Connector, Yellow	1
24	A4756	Male Turbine adapter	1	Hose Fittings			
25	A7537	Female air bleed Adapter	1	52	ST2163	5/8" black alloy hose adapter (male)	1
26	A5211	Brass air barb	1	53	A2069	S.S. hose clip 15/16" O.D	2
27	A4350	1/4" x 20 x 2 3/4" full thread hex	4	54	A2168	S.S. hose clip 7/8" O.D	2
28	A4177	Hose clamp size 28-1/2"	2	55	A2155	5/8" brass air hose joiner	1
29	A4222	Rubber hose, turbine exhaust	1	56	A2157	4 feet of flex hose, per foot	4
30	A4806	Base	1	57	A2111B	5/8" black alloy air hose adapter (male)	1
31	A4300	1/4" SAE Flat Washer, plated	15	58	A2167	20 feet of air hose, per foot	20
32	A4320	1/4" x 20 x 1/2" Hex Bolt, plated	12				

RUNNING MULTIPLE SPRAY GUNS WITH A TURBINE

Model 725, 825, 1025 and 1040VR have one air hose outlet on the side of the unit and are designed to run one spray gun. These models are equipped with an internal air relief valve to accommodate a non-bleed style spray gun (Apollo Model 7500).

It is possible to run the 4-stage turbine systems with two spray guns at the same time by installing Part #A4227, "Y" Connector to the turbine outlet port. It is important to note that if the "Y" Connector is installed and only one spray gun is operated, the 2nd outlet must be capped or closed so that performance to the single spray gun will not be affected.

GENUINE APOLLO ACCESSORIES

4500–2 Quart (2 Litre)
Fluid Feed System #A4500



Designed to be used with Apollo turbine systems: models 825, 900, 1025, 1040VR and 1100. Excellent in the shop or on site. Perfect for that larger job when a quart (litre) is just not enough or when greater spray gun mobility is needed to get into a tight corner.

Includes: oil-less mini air compressor, 2 quart (2 litre) non-stick coated pressure pot with stainless steel material tube, 20' (6m) or 30' (9m) fluid hose, air blanking screw and 4 wheels for easy mobility. Order part #A4500.

4550–Mobile Cart and
Fluid Feed System #A4550



Designed to be used with Apollo turbine systems: models 825, 900, 1025 and 1040VR. Excellent in the shop or on site. Perfect for larger jobs when a quart (litre) is just not enough or when greater spray gun mobility is needed to get into a tight corner. 2.5 gallon (10 litre) pressure pot, non-stick coated inside and out, with stainless steel fluid parts throughout. Large wheels provide easier mobility when going up and down stairs or curbs.

Includes: 2.5 gallon (10 litre) deluxe pressure pot, oil-less mini air compressor, 20' (6m) or 30' (9m) fluid hose, air blanking screw and cart. Order part #A4550.

GENUINE APOLLO ACCESSORIES

Using genuine Apollo accessories is important to the longevity, ergonomics and portability of your equipment. Other brands of accessories are not designed specifically with your Apollo brand equipment in mind and could cause abnormal functionality. For a complete list of Genuine Apollo parts please visit our website at www.hvlp.com or call a sales associate at 888-900-4857.

Turbine "Y" Connector #A4227



Pre- Filters



Model 725	#A4058
800S	None
825/900/1025	#A4096
1100/1200	2x #A4096
	1x#A4096

Handi-Hold™ Spray Gun Docking Station #A5326



Replacement Filters



Model 725	#A4129
800S	#A9012
825/900/1025	#A4171
1100/1200	#A4153



Fluid Hoses

A2113 - 6' (2m) x 1/4" (6mm) fluid hose with couplers
 A2059 - 20' (6m) x 1/4" (6mm) fluid hose with couplers
 A2060 - 40' (12m) x 1/4" (6mm) fluid hose with couplers
 A2114 - 6' (2m) x 3/8" (10mm) fluid hose with couplers
 A2159 - 20' (6m) x 3/8" (10mm) fluid hose with couplers
 A2160 - 40' (12m) x 3/8" (10mm) fluid hose with couplers



Turbine Air Hoses

A1068 - 24' (7m) x 5/8" (16mm) flex-air hose
 A1069 - 34' (10m) x 5/8" (16mm) flex-air hose
 A1070 - 44' (13m) x 5/8" (16mm) flex-air hose

Warranty

Two Year Limited Warranty

The machine and Equipment is WARRANTED by APOLLO SPRAYERS INTERNATIONAL, INC. for a total period of TWO YEARS on a PRO-RATED Basis (see Schedule below), from the ORIGINAL date of purchase by the ORIGINAL PURCHASER. Proof of purchase to be included and all SHIPPING CHARGES to be pre-paid.

APOLLO SPRAYERS INTERNATIONAL INC., upon examination of the machine/equipment will replace or repair at their discretion any defects in material or workmanship.

Warranty Schedule

Timeframe	Parts	Labor
First 6 months	No Charge	No Charge
Second 6 months	No Charge	No Charge
Third 6 months	50% of List	Charged
Final 6 months	75% of List	Charged

Labor will be charged at the current hourly rate, or specified job rate.

This WARRANTY does NOT include: misuse, damage, neglect, alterations, disassembled equipment or modifications, lack of maintenance, cleaning, water damage to electrical parts, INCORRECT VOLTAGE CONNECTION.

This Warranty is in lieu of all other express warranties, any WARRANTY implied by law, including but not limited to, implied Warranties of merchantability or fitness, is excluded to the maximum extent permitted by law and, if not excludable, is limited to the duration of the express Warranty.

No representative or person is authorized to extend this Warranty or to create for APOLLO SPRAYERS INTERNATIONAL, INC. any other liability in connection with the sale of any APOLLO SPRAYERS product. APOLLO SPRAYERS INTERNATIONAL, INC. shall not be liable for any consequential, incidental or special damages of any kind directly or indirectly resulting from breach of any express or implied warranty.

Some states do allow the exclusion or limitation of incidental or consequential damages or limitations on the length of any Warranty so that the above limitations and exclusions may not apply to you: however, to the maximum extent permitted under applicable law, the only rights and remedies shall be to obtain a replacement for any defective product.

This Warranty gives you specific legal rights and you may also have other rights which vary from State to State.

Apollo Sprayers International, Inc.

1030 Joshua Way, Vista, CA 92081

Parts & Service: (760) 727-8300

Fax: (760) 727-9325

Toll Free Sales: (888) 900-HVLP (4857)

www.hvlp.com