

Parts List 3

Diagram #	Part #	Description	Quantity
1	A4901	Fluid Tank	1
2	A4902	Lid Assembly	1
3	A4903	Handle	1
4	A4904	Gasket	1
5	A4905	Material pickup tube	1
6	A4906	Material filter housing	1
7	A4907	Filter base	1
8	A4908	Material filter element	1
9	A4909	Snap ring	1
10	A4910	T-bolt	4
11	A4911	Washer	4
12	A4912	Wing nut	4
13	A4913	Pressure regulator	1
14	A4914	Pressure gauge	1
15	A4915	On/Off valve	1
16	A4916	3-way block	1
17	A4917	1/4" X 1/4" adapter	3
18	A4918	3-way block	1
19	A4919	Adapter	1
20	A4920	Nut	1
21	A4921	Steel ball	1
22	A4922	Needle Rod	1
23	A4923	Spring	1
24	A4924	Safety valve housing	1
25	A4925	Adapter	1
26	A4926	O-ring	1
27	A4927	Release Valve	1
28	A4928	Material outlet adapter	1
29	A4929	Adapter	1
30	A4930	Cotter pin	4
31	A4931	C-snap ring	8
32	A4932	Wrench	1

ApolloSpray

Mobile Cart System

(A4550)

Assembly & Instruction Manual



Apollo Sprayers International, Inc.

1030 Joshua Way, Vista, CA 92083

(760) 727-8300

(888) 900-HVLP (4857) Sales

(760) 727-9325 Fax

www.hvlp.com

Table of Contents

- Unpacking.....3
- Attaching the turbine.....4
- Converting your spray gun.....5
- Connecting the hoses.....6
- Preparing to spray.....7
- Setting pot pressure.....8-9
- Cleaning your system.....10
- Cart system diagram #1.....11
- Cart system parts list #1.....12
- Spray gun diagram #2.....13
- Spray gun parts list #2.....14
- Pressure pot diagram #3.....15
- Pressure pot parts list #3.....16

Diagram 3

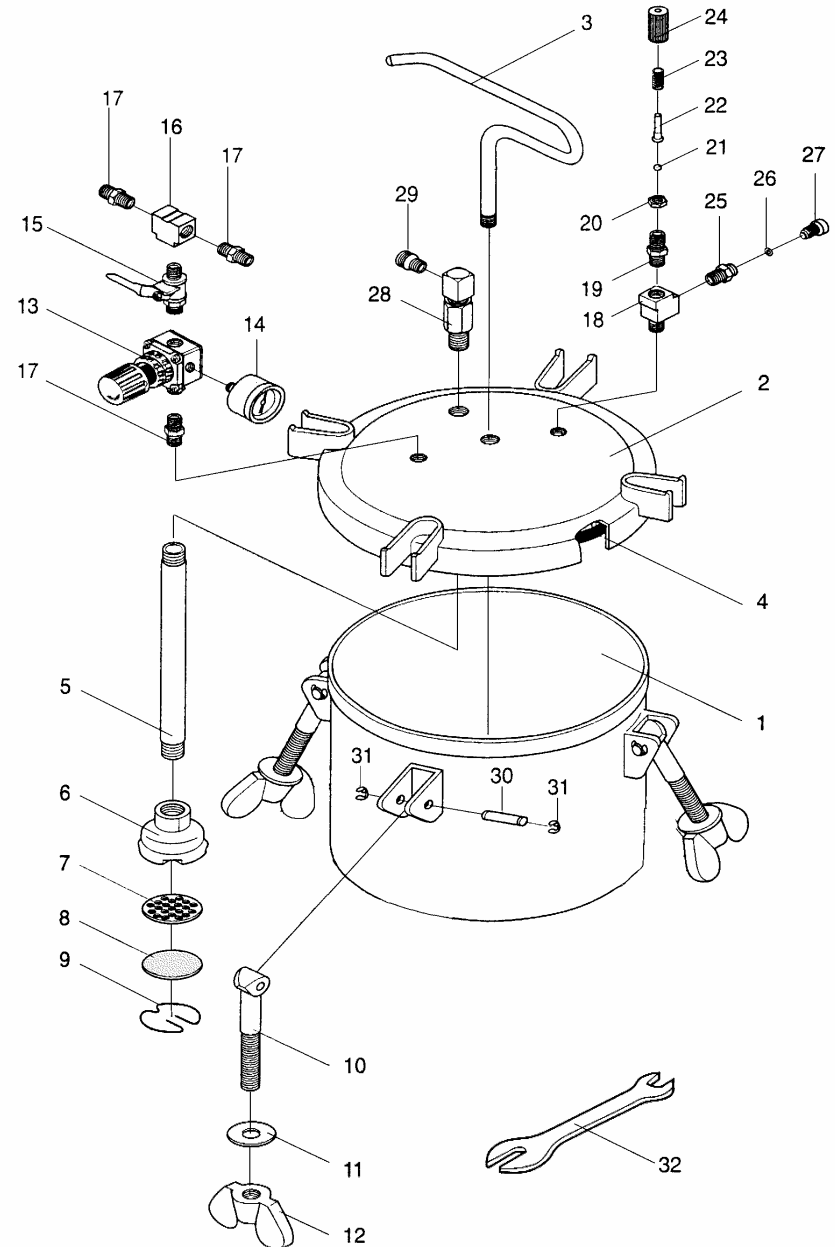

Parts List 2

Diagram #	Part #	Description
1	A5200	Air cap ring
2	A5201	Air cap # 1
2	A5297	Air cap # 2
3	A5203	Air distributor plate (stainless)
4	A5204	Air distributor spring (stainless)
6	A5206	Fluid nozzle/jet (stainless) .75MM
6	A5207	Fluid nozzle/jet (stainless) 1.00MM
6	A5208	Fluid nozzle/jet (stainless) 1.50MM
6	A5208-2	Fluid nozzle/jet (stainless) 2.00MM
6	A5209	Fluid nozzle/jet (stainless) 2.50MM
7	A5210	Fluid nozzle gasket
8	A5211	Air feed connector
9	A5212	Gun casting (main body)
10	A5213	Trigger bushing
11	A5214	Trigger pivot screw (stainless)
12	A5215	Trigger screw washer
13	A5202	Air blanking plug
13a	A5257	Air control texturing valve
14a	A5216	Upper port insert
14b	A5217	Air blanking plug
15	A5218	Needle (stainless) .75MM
15	A5219	Needle (stainless) 1.00MM
15	A5220	Needle (stainless) 1.50MM
15	A5220-2	Needle (stainless) 2.00MM
15	A5221	Needle (stainless) 2.50MM
16	A5222	Needle spring (stainless)
17	A5223	Flow screw insert
18	A5224	Material flow adjusting screw
19	A5225	Gun casting (handle)
20	A5226L	Handle tube
21	A5227	Air hose quick release coupler (male)
22	A5228	Gland seal
23	A5229	Gland seal (stainless)
24	A5230	Trigger (stainless)
25	A5232	Air feed tube and non-return valve
26	A5274	Center bolt/pick-up tube
27	A5271	Yoke
28	A5278	Lever
29	A5270	Cup top casting
30	A5266	90 degree miniature brass block
31	A5272	Cup top lock nut
32	A5280	Cup top gasket (White poly)
33	A5275	Quick release cup
33	A5277	Quick release cup (Teflon coated)
35	A5254	Fluid connector 3/8" (stainless)

Unpacking

Remove contents of the shipping box and lay out all of the pieces. The box should contain the following items:

1. Cart Base (pre-assembled)
2. Cart Handle
3. 2 ½ Gallon (10 liter) pressure pot with regulator, gauge, safety valve and connectors attached
4. 3/8" X 20' Black, lined fluid hose
5. Misc. nuts, bolts and washers (in a plastic bag attached to the side of the cart) for assembly
6. This Instruction manual.

Note: Do not place pressure pot onto the cart or insert handle into Cart Base until the Turbine unit is firmly bolted and secured to the Cart. Using the cart without the turbine installed can result in the cart tipping over.

You are now ready to assemble your Cart System for use. Please follow each step in the order presented. This will assure the correct use and best results.

Attaching the Turbine

1. Set the turbine unit on the Cart Base Plate (Diagram 1, #1) with the turbine air hose quick disconnect coupler facing forward. Line up the four holes on the turbine base plate with the four holes on the cart base plate. Secure the turbine unit to the cart base plate with the four ½" hex bolts, washers and nuts supplied in the plastic bag. Insert the bolts through the holes and place a washer over each of the bolts on the underside. Screw the four nuts onto the bolts and tighten. Be sure that the hex nut is tight enough so as not to vibrate loose.
2. Insert the Chrome Handle (Diagram 1, #31) into the Frame Tube (Diagram 1, #6). Be sure to evenly push the handle all of the way down so that the spring loaded buttons lock into place securing the handle firmly.
3. Plug the turbine unit into the electric outlet on the side of the Cart (Diagram 1, #25).
4. Place the 2 ½ gallon (10 liter) pressure pot onto the pressure pot deck (Diagram 1, #20). Align the fluid outlet toward the front of the cart. This will position air inlet toward the back of the cart.

Note: The Pressure Pot Support Rings (Diagram 1, #29) can be adjusted for use with different size pressure pots. To adjust simply remove the four securing bolts (Diagram 1, #19). Align the holes up to the smaller settings and re-insert the four bolts, washers and nuts. Make sure to tighten the bolts back up.

Diagram 2

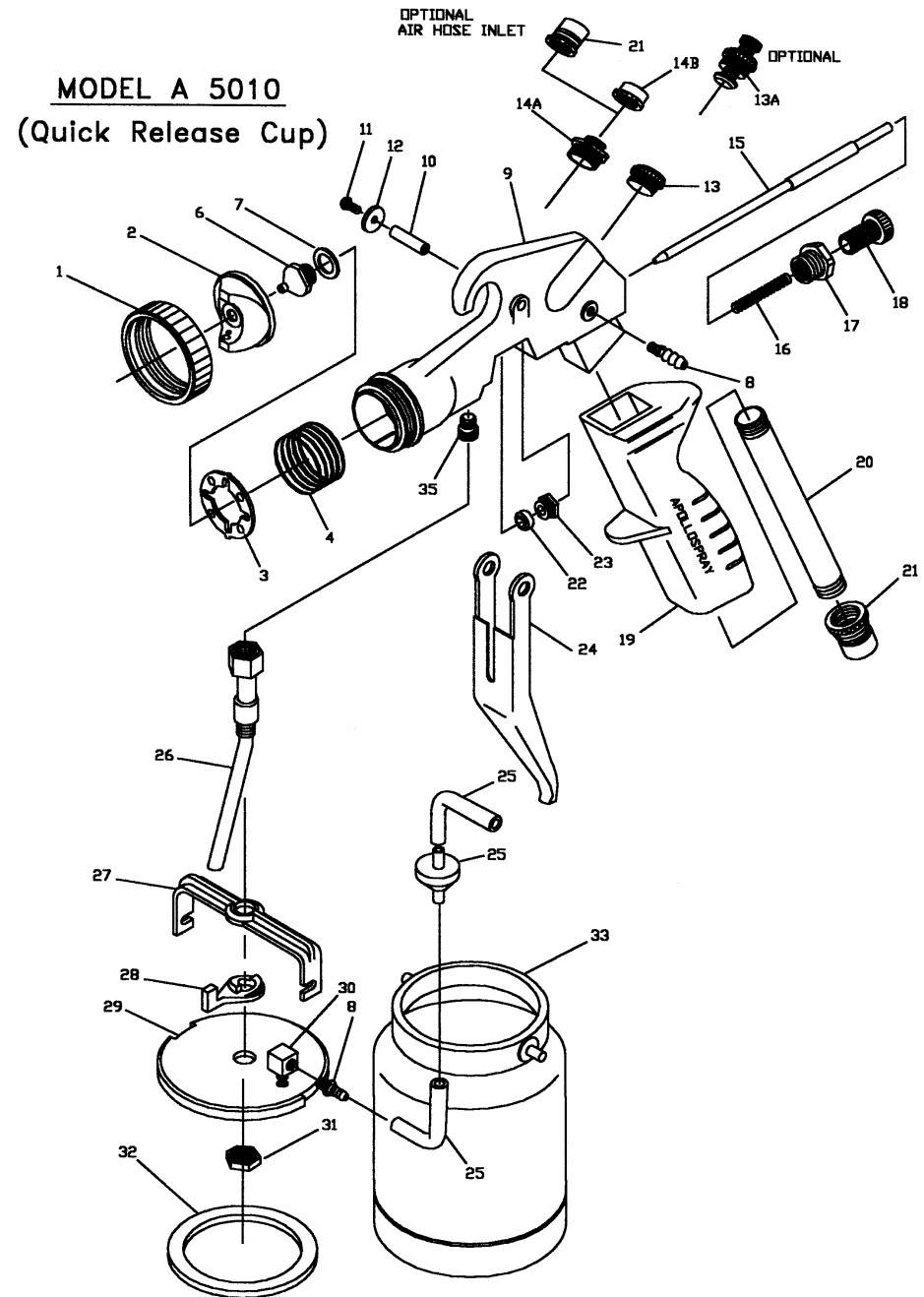

Parts List 1—Cart System

Diagram #	Part #	Description	Quantity
1	A4554	Cart Base Plate Paint blue	1
2	A4555	Cart Axle (Zinc Plated)	1
3	A4556	Wheel Spacer (6061 alu.)	2
4	A4558	10" x 1 3/4" wheel	2
5	A4374	1/2" Axle cap	2
6	A4551	Frame Tube (Chrome)	2
7	A4559	Rubber tip for Frame tube	2
8	A4560	Handle button	2
9	A4364	1/4" x 20 x 1 1/4" hex bolt plated .5.	4
10	A4300	1/4" SAE F/W plated washer	20
11	A4308	1/4" X 20 hex nuts plated	20
12	A4198	110V mini compressor unit	1
13	A4998	Pressure regulator	1
14	A4503	1/8" male NPT X 1/4" male hose barb 90°	1
15	A4033	Air hose clip S.S.	2
16	A2116	1/4" air hose, per foot	3
17	A2119	1/4" X 1/4" female swivel barb	1
18	A4026	Quick connect female with 1/4" male thread	1
19	A4320	1/4" x 20 x 1/2" hex bolt plated .5.	16
20	A4553	Pressure pot deck	1
21	A4318	6-32 X 1/2" phill pan m/s plated	4
22	A4307	6-32 Hex M/S nuts plated	2
23	A4051	Cable clamps, black	2
24	A4557	Outlet box (plastic)	1
25	A4197	Outlet 15Amp-125 Volt	1
26	A4053	Flexible Cord Protector	1
27	A4028	8 foot Power Cord	1
28	A4178	Large Ring Terminal	3
29	A4552	Support ring for pressure pot.	2
30	A4113	2.5 gallon pressure pot	1
31	A4006	Handle (Chrome)	1
32	A4042	Handle Grip	2

Converting your Spray Gun

1. Disconnect the upper section of the air feed tube from the non-return valve (Diagram 2, #25) leaving the valve attached to the lower section of the tube. This will provide safe storage while using the spray gun in the production mode.
2. With a 3/4" open end wrench, loosen the Center Bolt (Diagram 2, #26) and remove the entire cup assembly. Set aside.
3. Remove the air feed connector (Diagram 2, #8) along with the upper section of the air feed tube using a small open end 1/4" wrench. Install the blanking screw, provided in the plastic bag (10/32") to close the hole where you removed the air feed connector. Store the air feed connector with tube attached in the cup assembly for future use.

Connecting the Hoses

1. Attach the turbine Air Hose to handle of spray gun with the quick disconnect coupler (Diagram 2, #21). Insert the male coupler on the other end of the Air Hose into the quick disconnect coupler on the turbine unit. Refer to turbine manual for additional details.
2. Locate the Paint outlet (underneath the front of the spray gun). Wrap a strip of Teflon tape around the threads on the Fluid Connector (Diagram 2, #35). Screw one end of the Black fluid hose onto the Fluid Connector. Secure and tighten.
3. Locate the Paint Outlet on the lid of the 2 ½ gallon (10 liter) pressure pot. (Diagram 3, #28, 29) (Marked on the pot). Wrap a strip of Teflon tape around the threads of the Fluid Connector.
4. Attach the remaining end of the black fluid hose to the Paint Outlet (Diagram 3, #28, 29) (Marked on the pot). Secure and tighten.
5. Locate the small black air compressor (Diagram 1, #12) under the Pressure Pot Deck (Diagram 1, #20). Connect the female quick disconnect (Diagram 1, #18) on the air hose from the compressor to the male quick connect (Diagram 3, #17), marked "Air Inlet" on the pressure pot.
6. Your cart system is now set up for production spraying.

Diagram 1

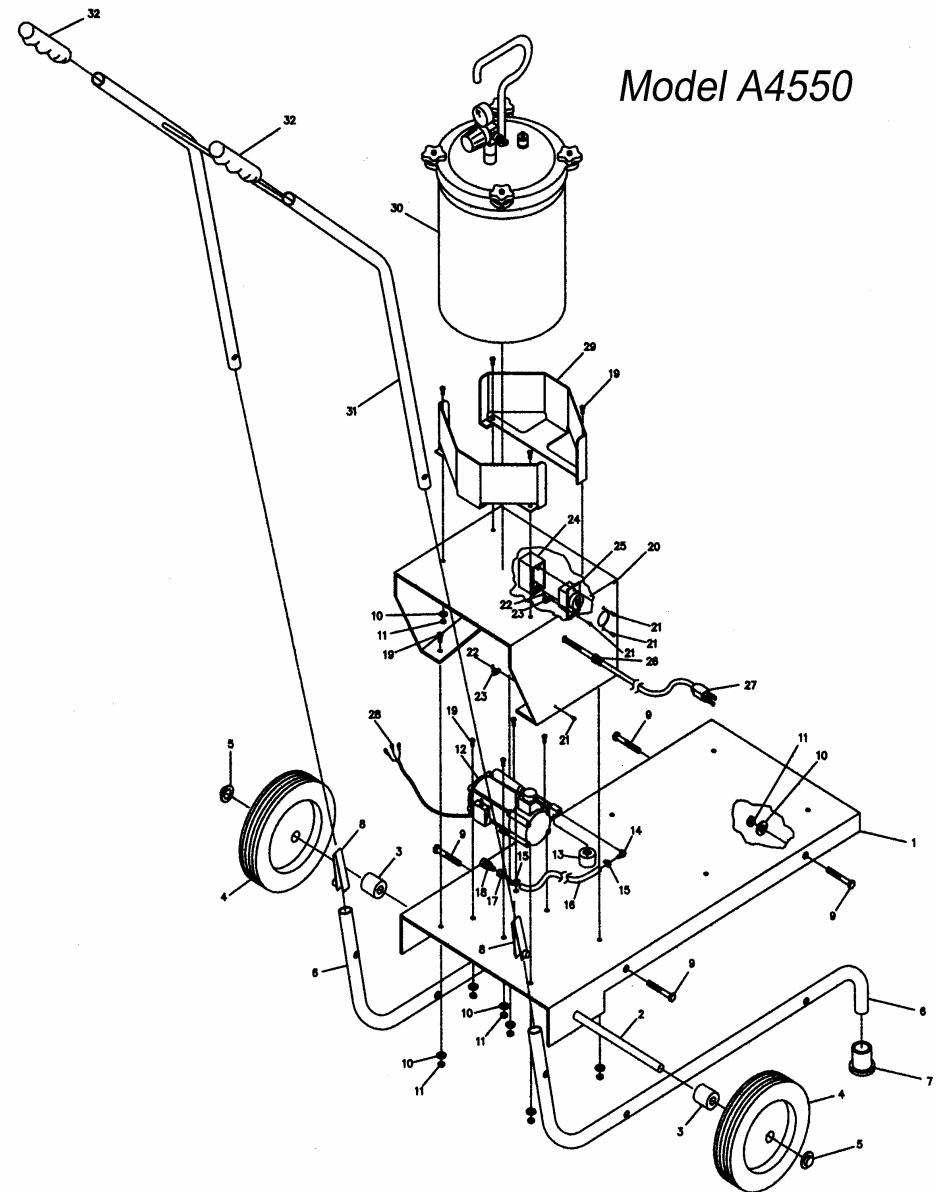

Cleaning the System

1. When you are finished spraying for the day, it is wise to clean your spray gun, the pressure pot and the fluid line. While it is possible to leave fluid in the pressure pot between uses, be sure that all materials are compatible with the components of the pressure pot to avoid fluid contamination. Never leave catalyzed or epoxy materials in the pot beyond suggested pot life of the fluid product to avoid set up and hardening of the coating and damage to the pot, its components, fluid lines and the spray gun.
2. Release all air pressure in the pot. Locate the Air Release Valve and turn anti-clockwise. You will hear hissing. The pressure in the pot is now releasing. You will also notice that pressure gauge will lower to "0 PSI". Once there is no more pressure in the pot, it is safe to open.
3. Following normal cleaning procedures of the spray gun as outlined in the Turbine instruction manual and information supplied with the spray gun.
4. Clean pressure pot and fluid lines with appropriate cleaning materials for the product being sprayed, exercising all cautions depending on the cleaning material being used. Spray cleaning fluid from the pressure pot through the fluid line and the spray gun until you are satisfied that all paint or coating material has been flushed through the system.
5. Store equipment for use in the future.

TIP: To easily remove the fluid in the fluid hose without wasting any, cup your hand over the front of the spray gun. With the pot air pressure at "0" psi and the turbine running, pull the trigger. The turbine air will be forced through the spray tip into the fluid passages and hose,

Preparing to Spray

Note: Never open the pressure pot without turning off the air compressor and releasing the air pressure in the pot with the Air Pressure Release Valve. (Open valve until all pressure is released. Pressure Gauge will read "0 PSI" when there is no more pressure in the pot).

1. Prepare your paint or coating for spraying. Adjust the viscosity as recommended by the coating manufacturer. Refer to your turbine instruction manual for viscosity guidelines.
2. Carefully loosen the Wing Nuts (4 of them) (Diagram 3, #12) to remove the pot lid. Open the pressure pot. (Note: You may have to disconnect the air hose from the compressor when opening the lid. Be sure to reconnect air hose when the lid is closed again). You can either pour your coating into the pot, or you can insert a smaller container inside the pot, making sure that the Material Pick-up Tube (Diagram 3, #5), is inserted into the coating. Place the lid back on top of the pressure pot making sure that it is properly seated. Bring each Wing Nut back into place and secure the lid firmly.
3. Secure each wing nut into place following the sequence on the diagram to the right, rotating an even amount of pressure on each one until each is tight and secure.
4. Plug the power cord from the cart (Diagram 1, #27) into a 110 volt grounded receptacle. **Caution:** If you are using an extension cord, it is imperative to use at least a 12 gauge cord to avoid damage to electrical components.

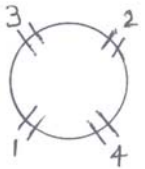

Setting the Pot Pressure

5. Turn on the mini-compressor unit (Diagram 1, #12). Locate the on/off switch which is mounted on top of the silver box on the compressor located at the back of the cart. Move the switch to the “on” position. You should hear the compressor begin to pressurize the pot.
6. Look at the pressure gauge (Diagram 3, #14) located on top of the pressure pot lid. You will notice the gauge begin to rise as the pressure builds in the pot. The pressure gauge will tell you how much air pressure is in the pressure pot. Generally you will only need about 5 PSI for most light to medium viscosity fluids. Increasing pressure should only be necessary for high viscosity fluids or when the fluid must travel up hill for more than 10 feet.
7. Attached to the pressure gauge is the pressure regulator (Diagram 3, #13). To decrease pressure, rotate the knob on the pressure regulator anti-clockwise. To increase pressure rotate the knob clockwise. Stop when the desired pressure is achieved. Your compressor is set to shut off when the desired pressure is reached and back on when the pressure drops down. This has been pre-set at the factory and should not be readjusted.
8. If the pressure rises above the desired maximum, you can release pressure in the pot with the Air Release Valve (Diagram 3, #27) and control the maximum amount of pressure with the Pressure Regulator (#13).

Note: The following tasks should NOT be performed with the turbine running.

9. When the air pressure in the pot has been set at the desired pressure and the fluid has been added to the pressure pot, pull the trigger back on the spray gun. **(Caution: Don't point the spray gun at yourself or anyone else, you can cause bodily injury. Make sure that you hold the gun safely away from you.)** The first time you use the pressure pot each day, or after the pressure pot has been depressurized, it will take a minute or two for the fluid to reach the spray gun. When the fluid reaches the tip of the spray gun a stream of fluid will flow out. This is known as “Priming” the spray gun.
10. A good indication of pot air pressure can be determined by observing the fluid stream from the spray tip (Diagram 2 #6). When the trigger is pulled without the turbine running the fluid stream should extend out 2 1/2” (6.35cm) before the stream begins to bend. If the fluid extends further than 2 1/2”, then you have too much air pressure. If it is shorter than 2 1/2”, then you need more air pressure. Adjust accordingly.
11. Once this is adjusted, locate the black ring on the pressure regulator and screw it back to the pressure regulator knob. This will lock the regulator settings in place.
12. Turn on the turbine system. You should now be able to spray continuous volume from the pressure pot.

Note: Never open the pressure pot without turning off the air compressor and releasing the air pressure in the pot with the Air Pressure Release Valve. (Open valve until all pressure is released. Pressure Gauge will read “0 PSI” when there is no more pressure in the pot).